

-01P2

Montageanweisung / Installation instructions / Instruction de montage / Istruzioni di montaggio
montagehandleiding / Instrukcja montażu / Montaj talimatlar / Osszeselési útmutató / Nàvod k montáži /
Nàvod na montaž / Instrucțiune de montaj / инструкции по сборке / Montaj talimatina / Monteringsanvisningar/
Upute za montažu / Instrucciones de Montaje / Navodila za montažo

ROMANE

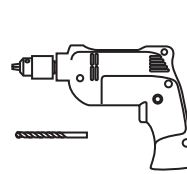
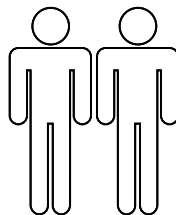
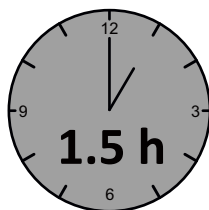

D – bitte lesen sie diese montageanleitung gut durch,
Da wir für fehler, die durch falsche montage entstehen,
Keine haftung übernehmen!

Gb – please read these installation instructions
Through carefully as we cannot accept any liability
For faults occurring as a result of incorrect installation!

Cz – přečtete si prosim pozorně tento návod k montáži,
Aby jste předešli chybám vzniklých špatnou montáží,
Za které neručíme!

F – veuillez lire attentivement cette notice de montage,
Car nous déclinons toute responsabilité en cas d'erreurs
Découlant d'un montage erroné !

I – prego leggere attentamente le istruzioni per il montaggio,
Poiché decliniamo qualsiasi responsabilità
Per difetti derivanti da montaggio errato.

S - läs monteringsanvisningarna noggrant.
Vi avstår oss allt ansvar för defekter som
Uppstår p.g.a. Felaktig montering.

Hr – pažljivo pročitajte upute za montažu,
Jer otklanjamo svaku odgovornost za pogreške
Nastale uslijed pogrešne montaže.

Slo – prosimo, da pozorno preberete navodila za montažo,
Saj zavračamo vsakršno odgovornost za napake,
Ki bi nastale zaradi napačne montaže.

Nl – leest u alstublieft deze montagehandleiding goed door,
Voor fouten door verkeerde montage zijn wij niet verantwoordelijk.

Pl – prosze uwaznie zapoznac sie z instrukcja montazu,
Poniewaz nie ponosimy odpowiedzialnosc za niewlasciwy montaz.

Hu – Kérjük, olvassa el figyelmesen
ezt az összeszerelési útmutatót,
mert a helytelen összeszerelésből
a dódó hibákért nem vállalunk felelősséget!

SK – Prosíme, dobre prečítajte si tento návod na montáž,
pretože nepreberáme žiadne ručenie za chyby,
ktoré vzniknú na základe chybnej montáže!

RO – Vă rugăm să cititi cu atenție aceste instrucțiuni
de montaj deoarece nu preluăm garanția pentru defecte
ce apar datorită unui montaj incorect!

RUS – Пожалуйста, внимательно ознакомьтесь ù
с данной инструкцией по монтажу, поскольку мы не
несем ответственности за ошибки, причиной которых
является неправильный монтаж.

TU – İlkonce kullanma klavuzunu iyi okuyun,
yalnis montaj yapasaniz bunun sorumlusu biz degiliz.

ES – Se ruega leer con atención las instrucciones
de montaje debido a que declinamos cualquier
responsabilidad
por defectos derivados de un montaje erróneo.

SERVICEKARTE

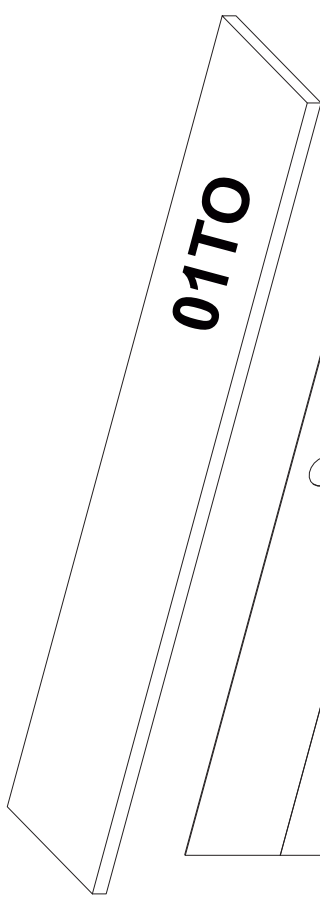
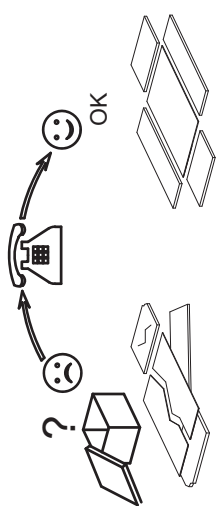
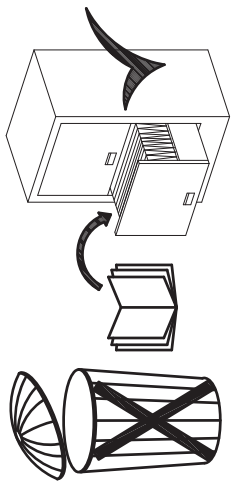

01TO

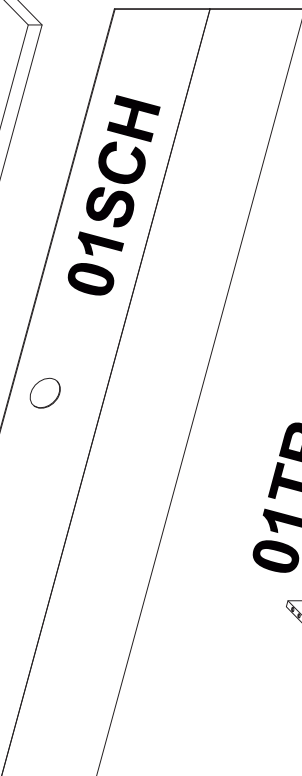

01SCH

01TR

01TR

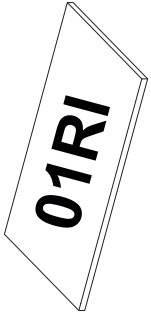
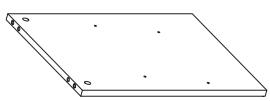
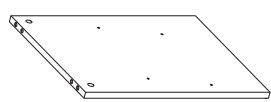

01RI

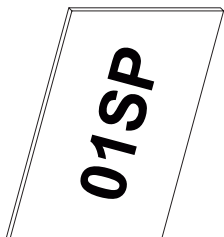

01SP

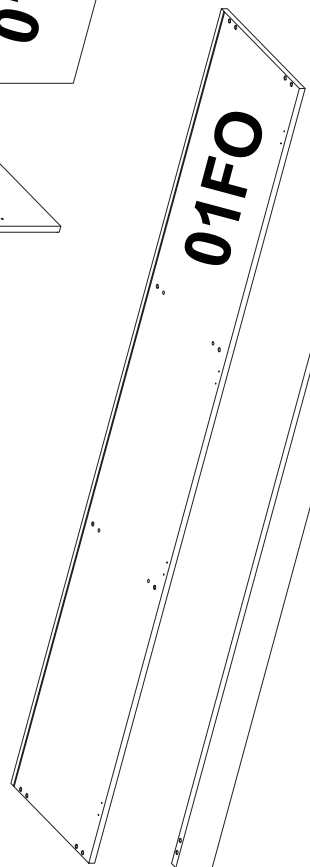

01FO



01FAF

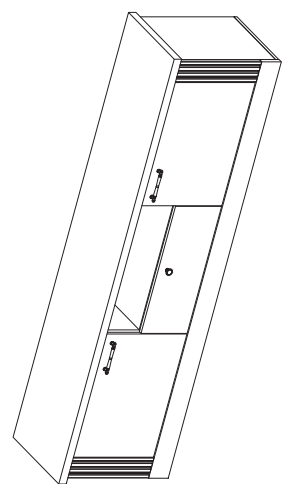

01FI

01PETI

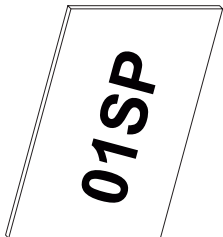
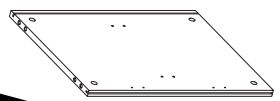

01SP



01FA

07SPO

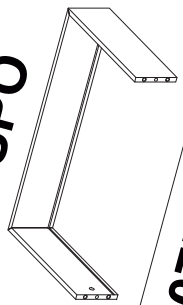

07FC

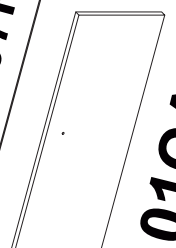

01CA

01PETI

01FI

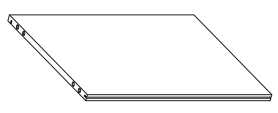

01FA

SERVICEKARTE

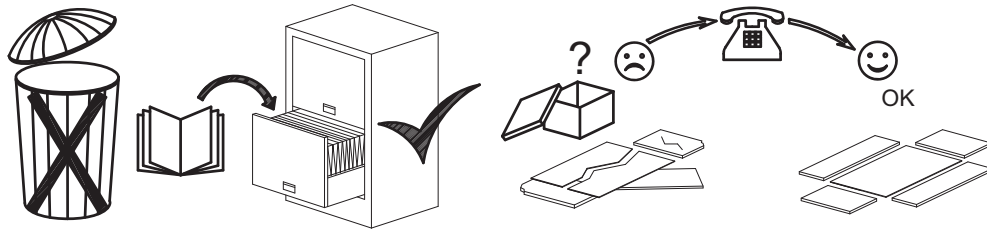

H2E

x4

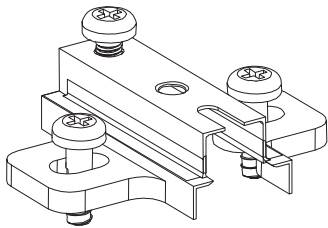

POM

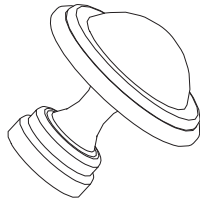

x1

CL

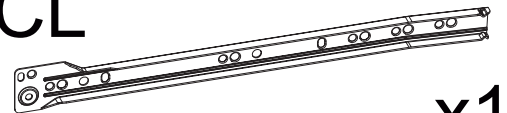

x1

C90

x4

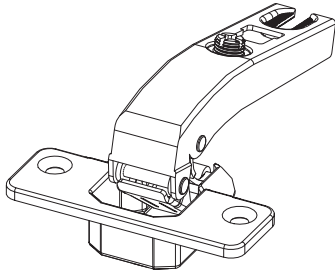

T420

x1

CR

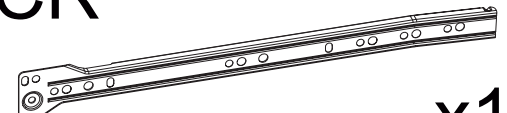

x1

V415

ø4x15 mm x8

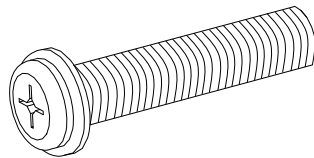
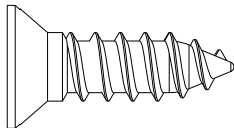

ø4x20 mm

CL

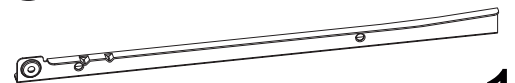

x1

CR

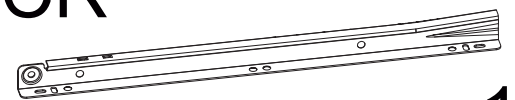

x1

P

ø60

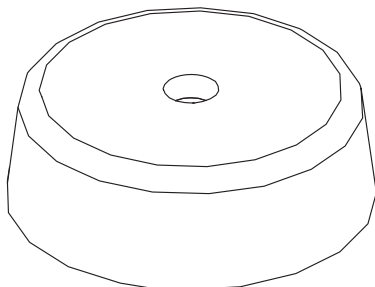

x6

MAN

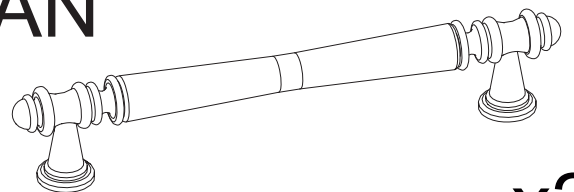

x2

V4530

x6

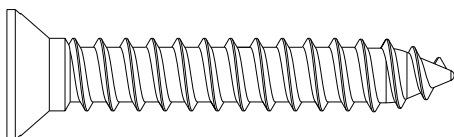

ø4.5x30 mm

T420

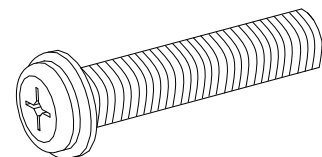

x4



ø4x20 mm

ONDERDELEN LYST-SERVICEKARTE-FORMULAIRE DEMANDES SAV-SPAREPARTS LIST-SCHEDADI SERVIZIO

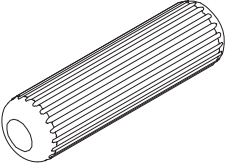
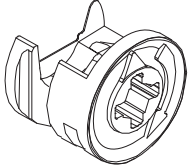
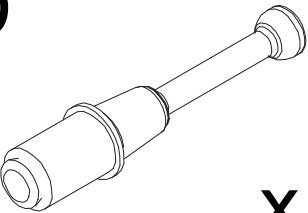
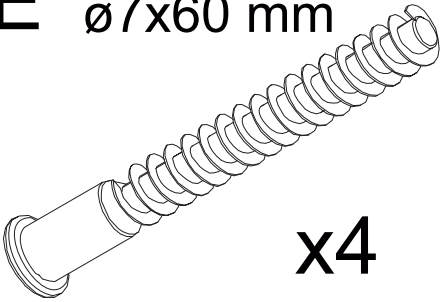
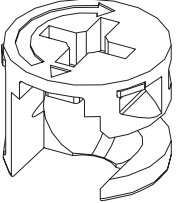
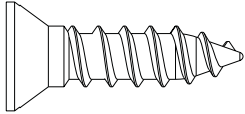
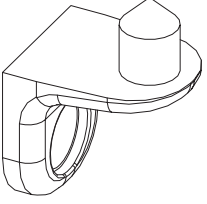
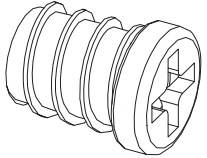
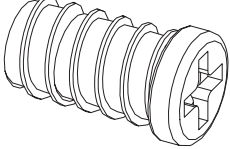
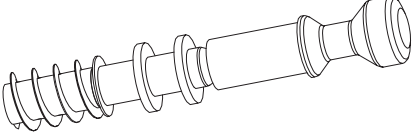
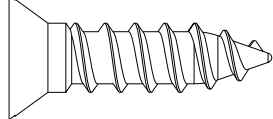
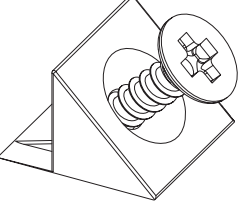
BESLAG-BESCHLAEGE - QUINCALLERIE - HARDWARE - FERRAMENTA

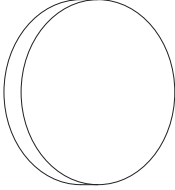
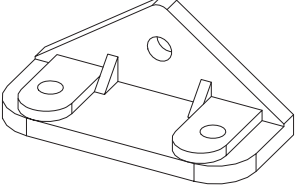
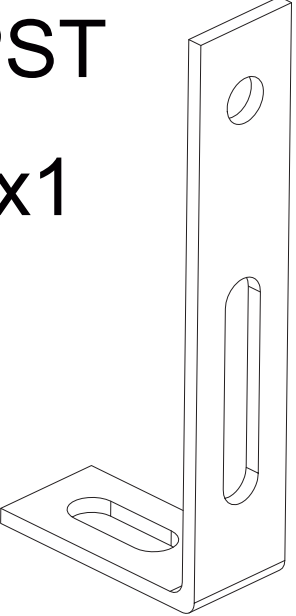
- B**  **x24**
- C**  **x12**
ø15
- D**  **x12**
- E**  **x4**
ø7x60 mm
- C1**  **x2**
- V3516**  **x4**
ø3.5x16 mm
- R1**  **x4**
- M9**  **x4**
ø6.3x9 mm
- M11**  **x4**
ø6.3x11 mm
- D1**  **x2**
- V418**  **x26**
ø4x18 mm
- F**  **x16**
- G**  **x4**
- V**  **x4**
- P7**  **x8**
- PST**  **x1**

1

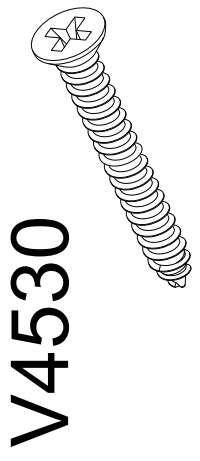

V4530

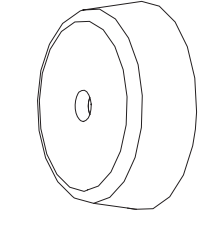

P

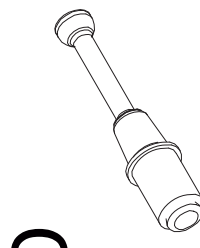

D

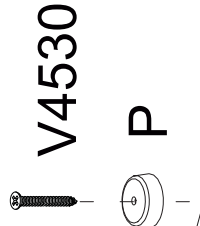

x6 Ø4.5x30 mm X6

x4 Ø60

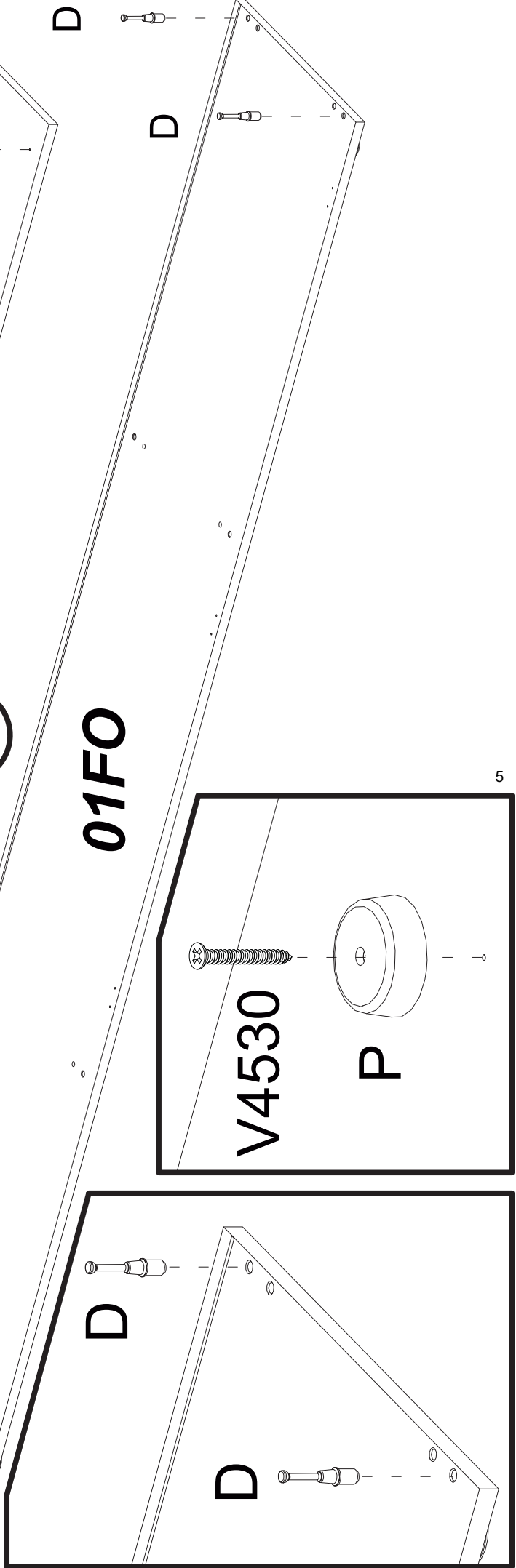
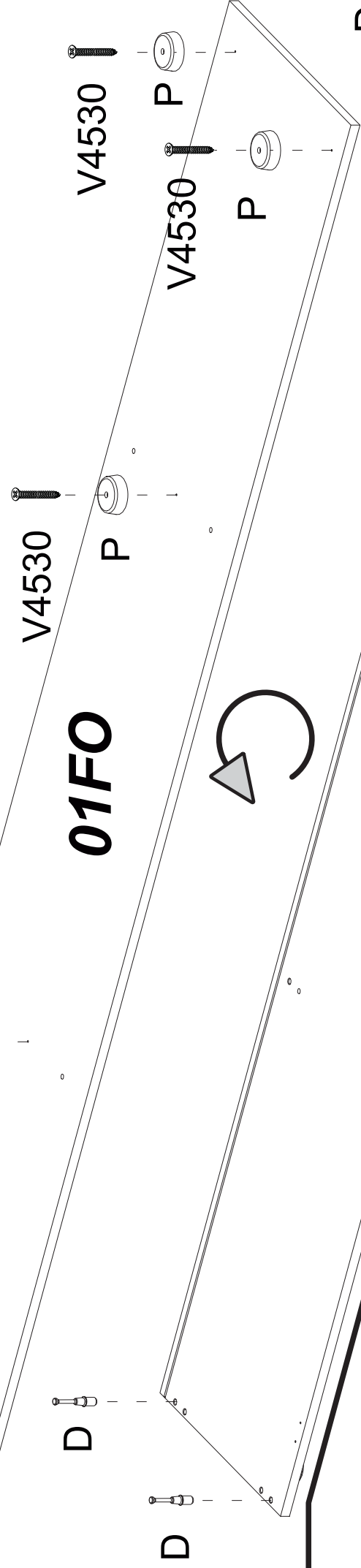

2a

M11

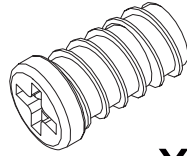

x4

CL

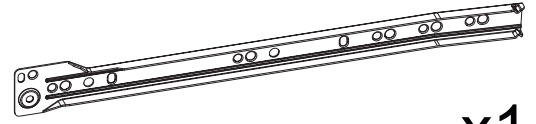

x1

CR

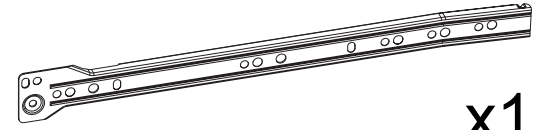

x1

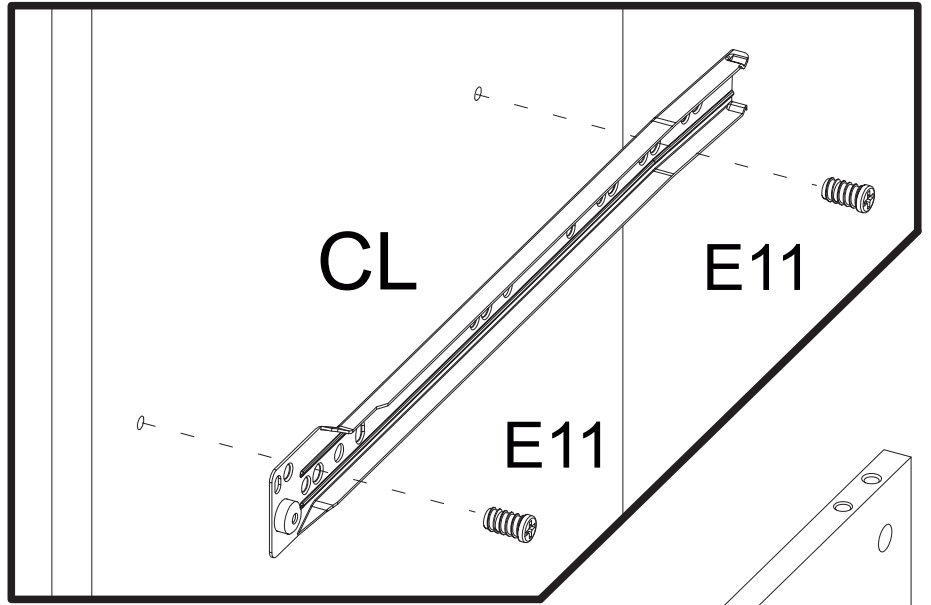
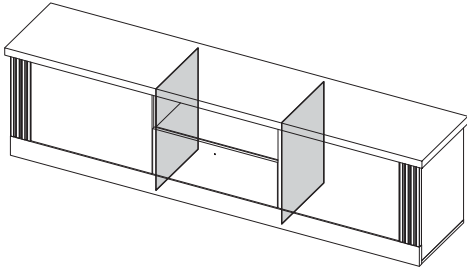

CL

E11

E11

01TR

CL

CR

01TR

2b

R1

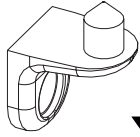

x4

M9

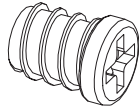

x4

B

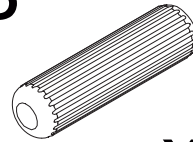

x8

D

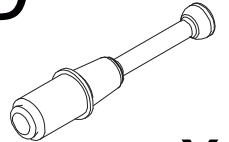

x4

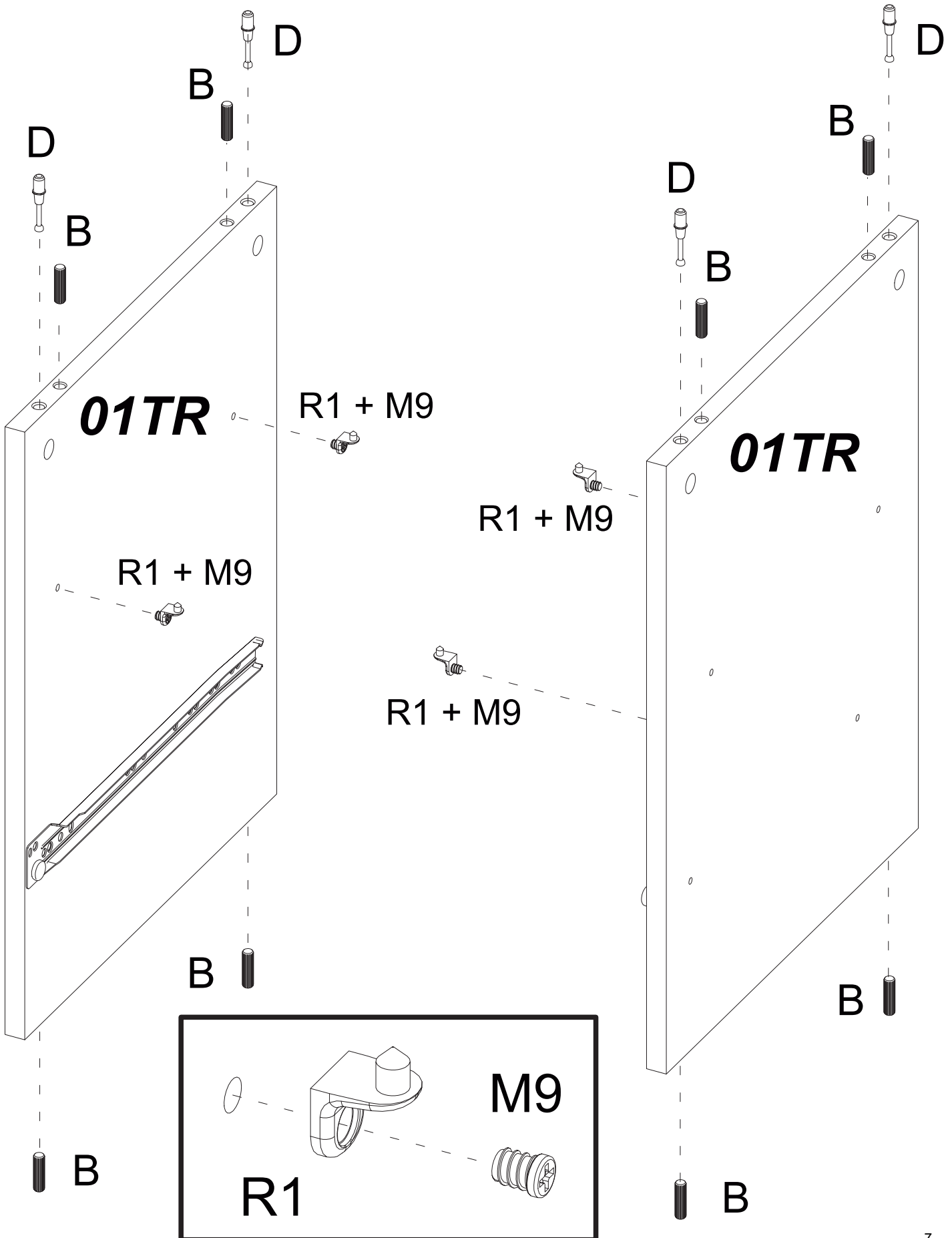

3



B

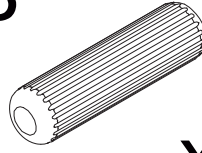

x8

D

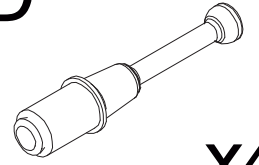

x4

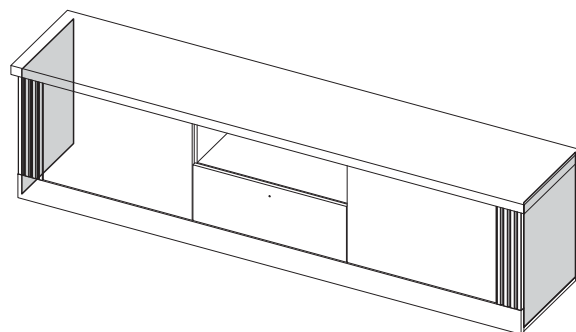
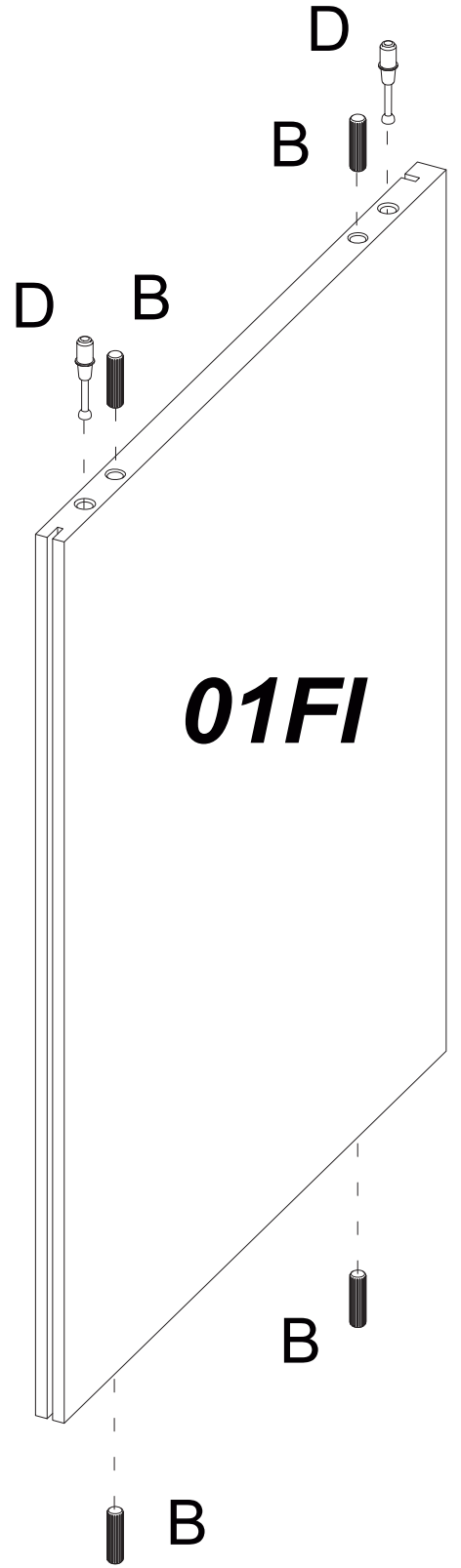

4

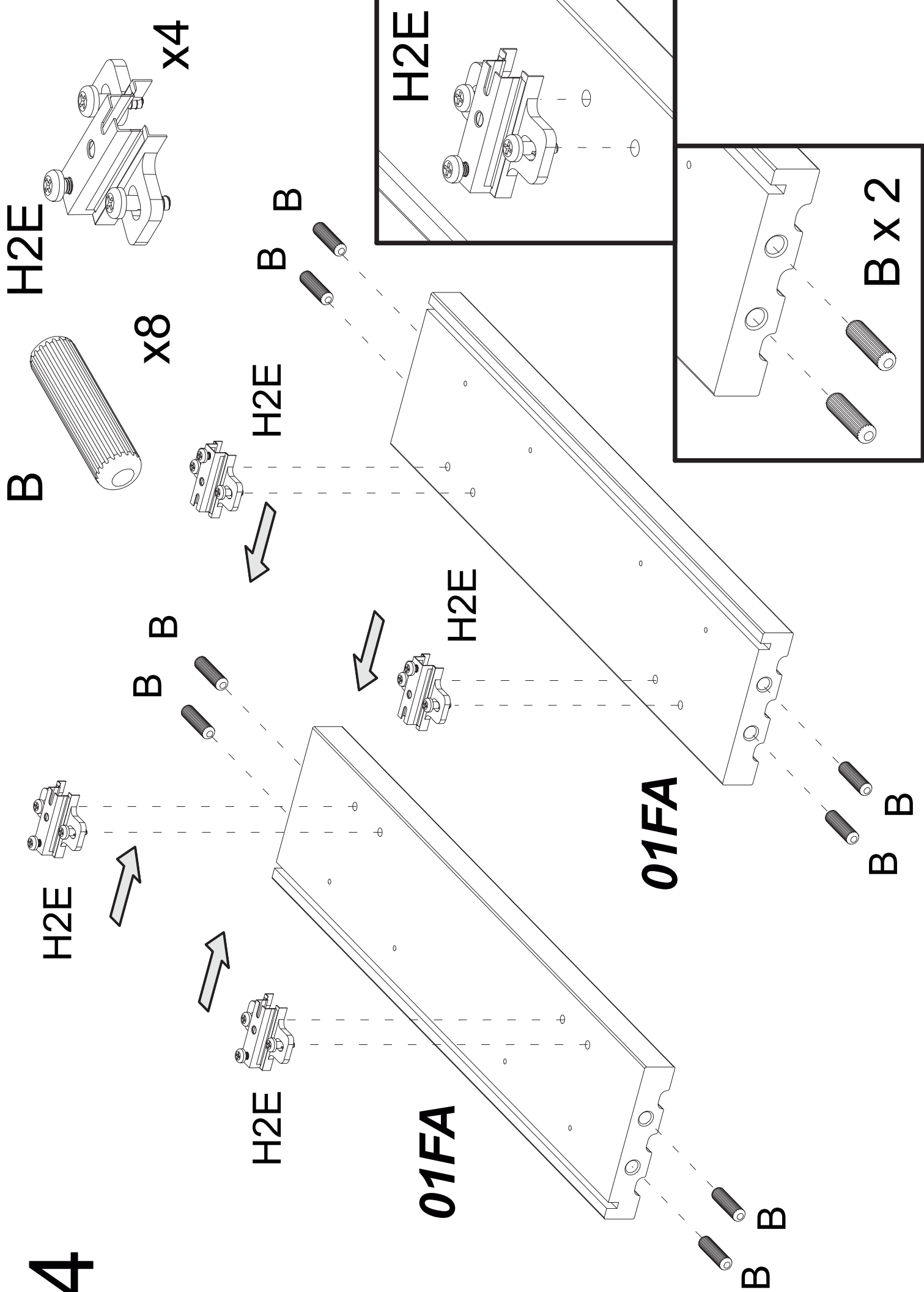

5

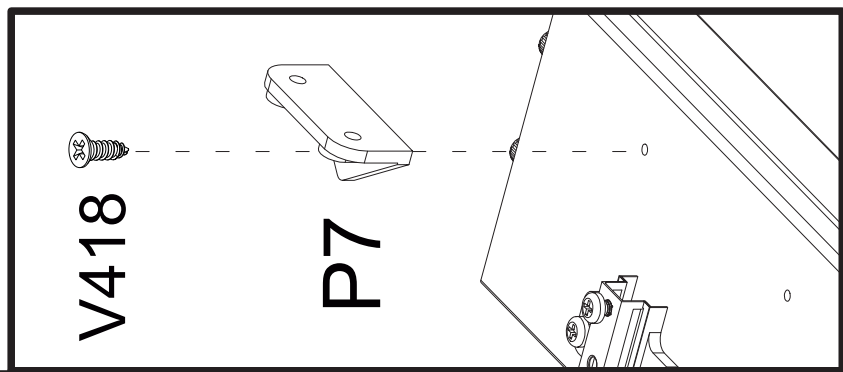
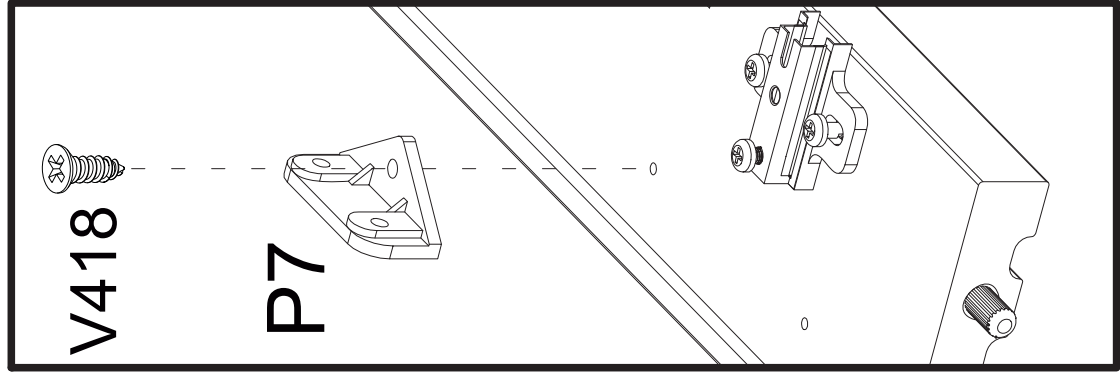
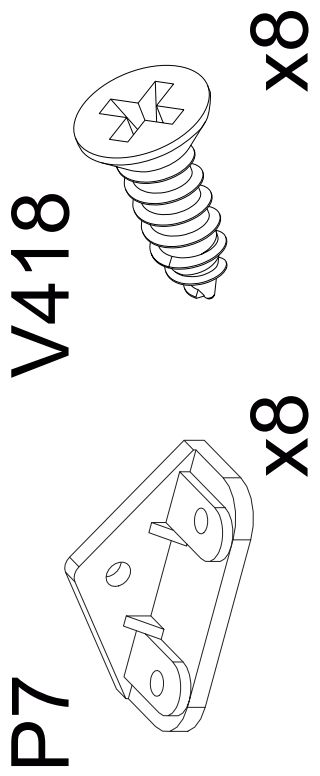
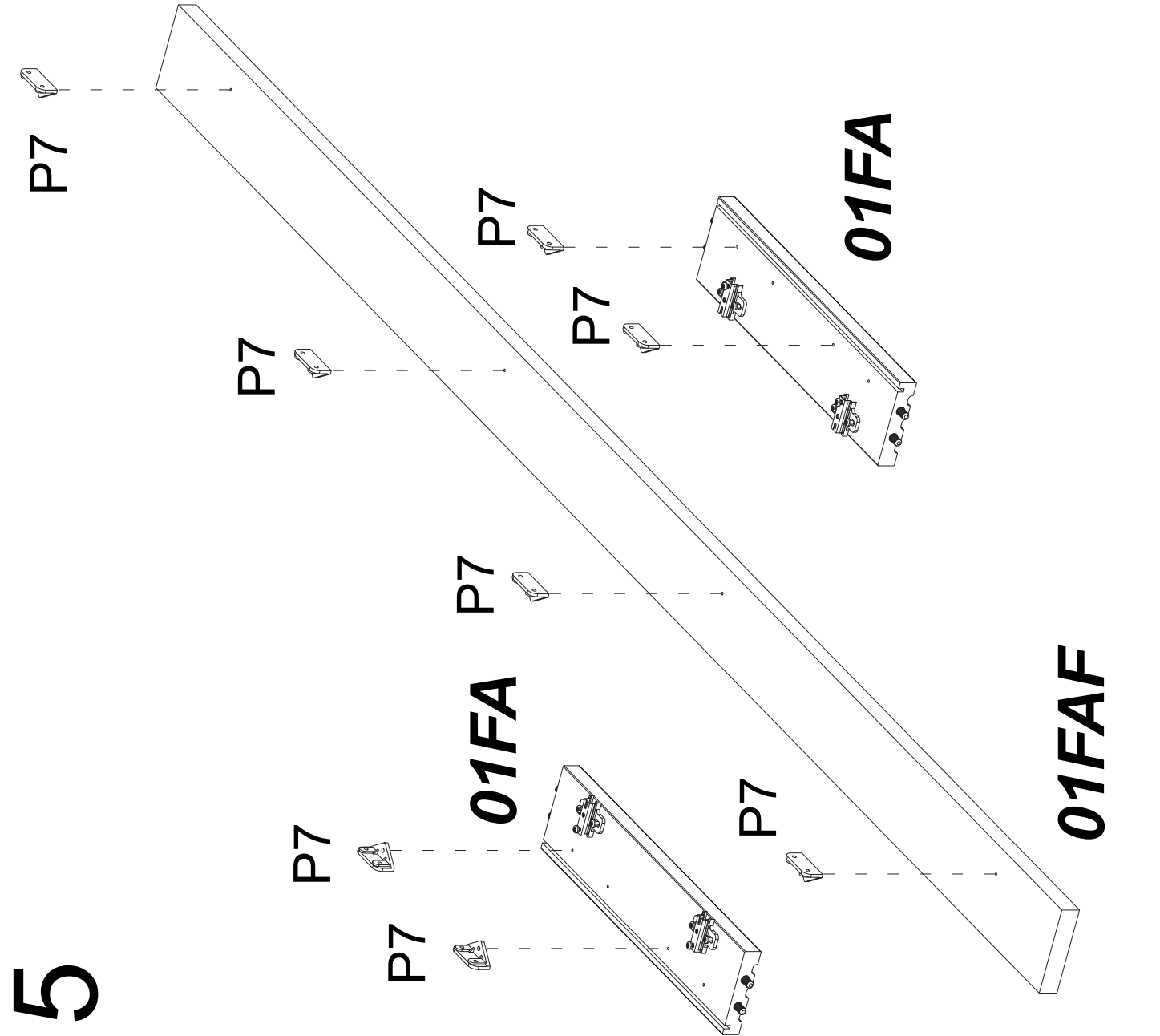

6

01FI ↓

01TR x 2



01FI ↓

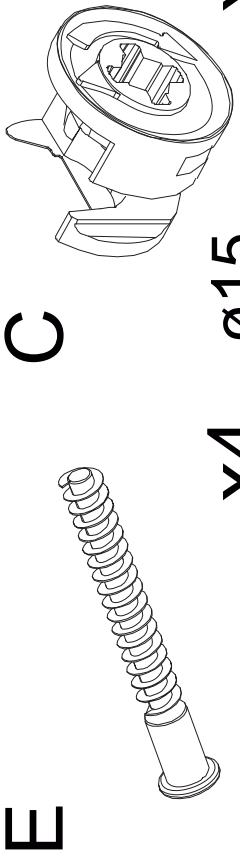

x4 ø15

x4

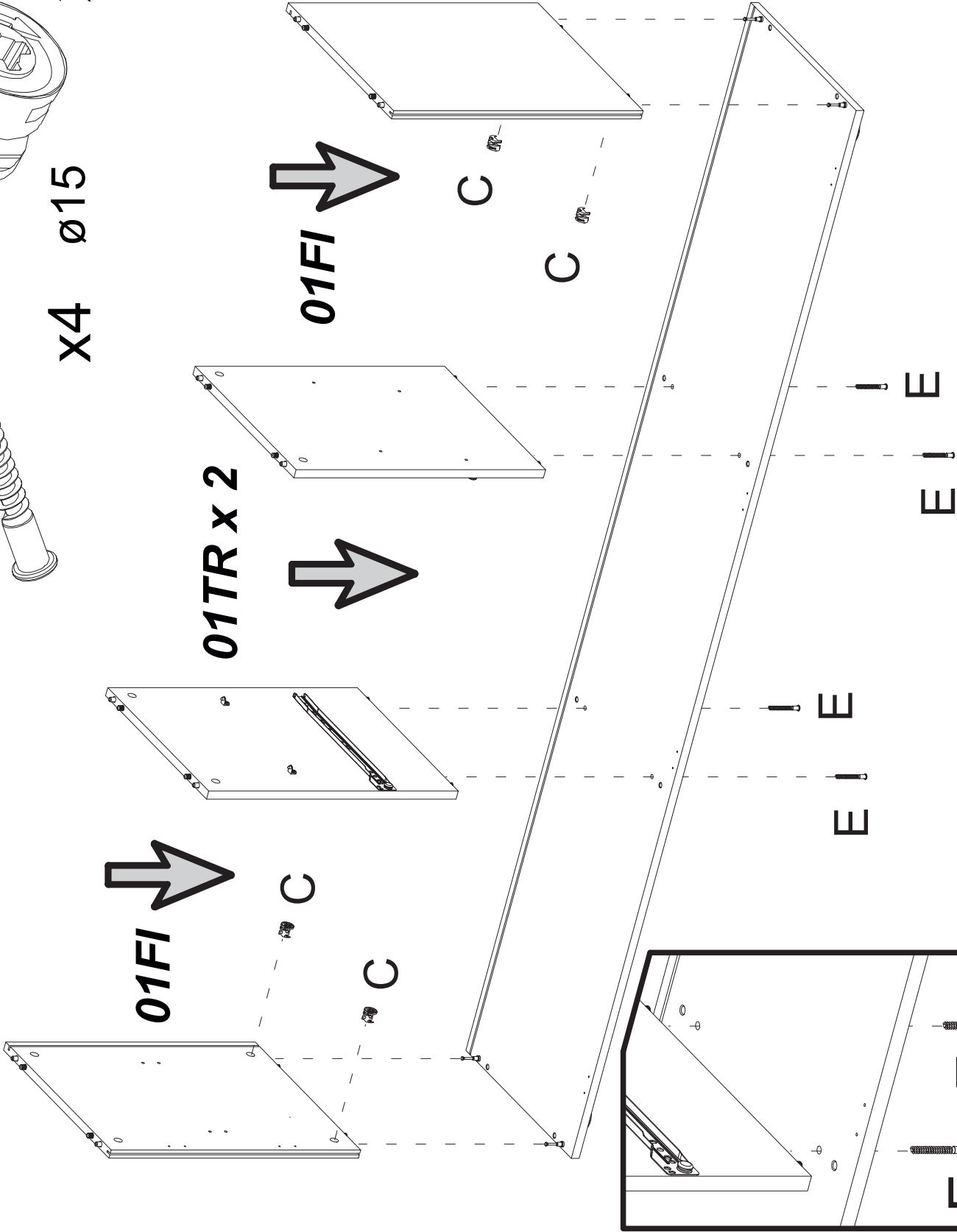
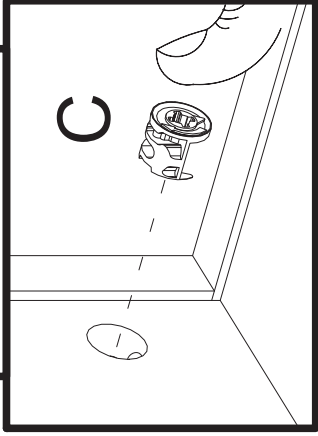
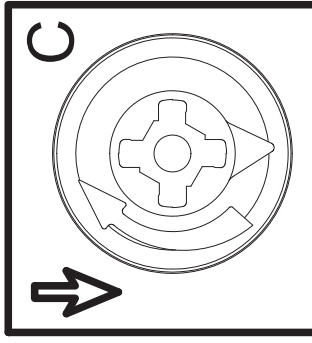
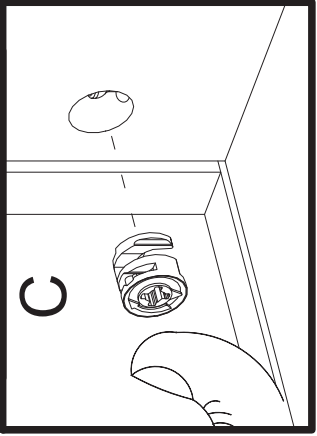
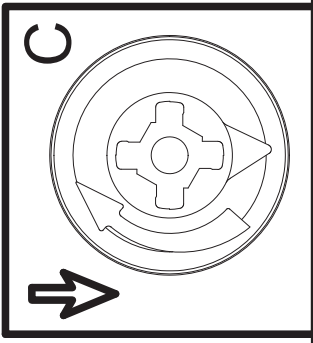

E E

7

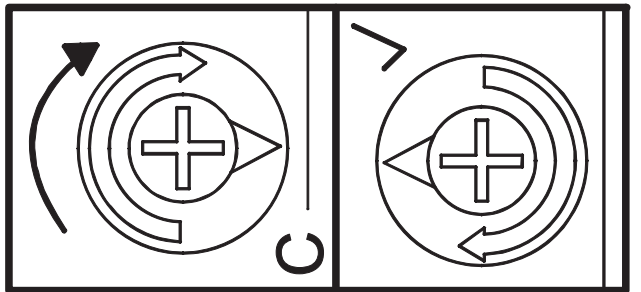
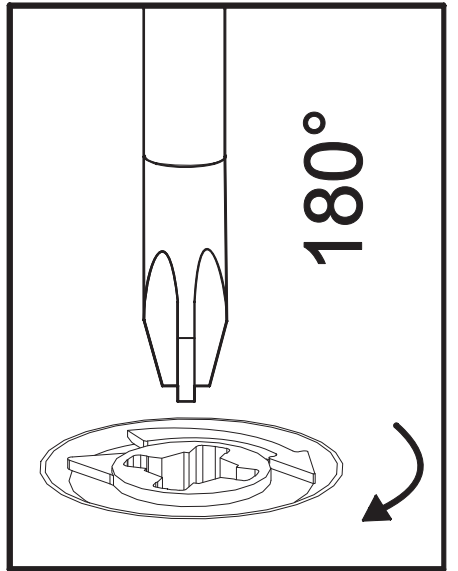
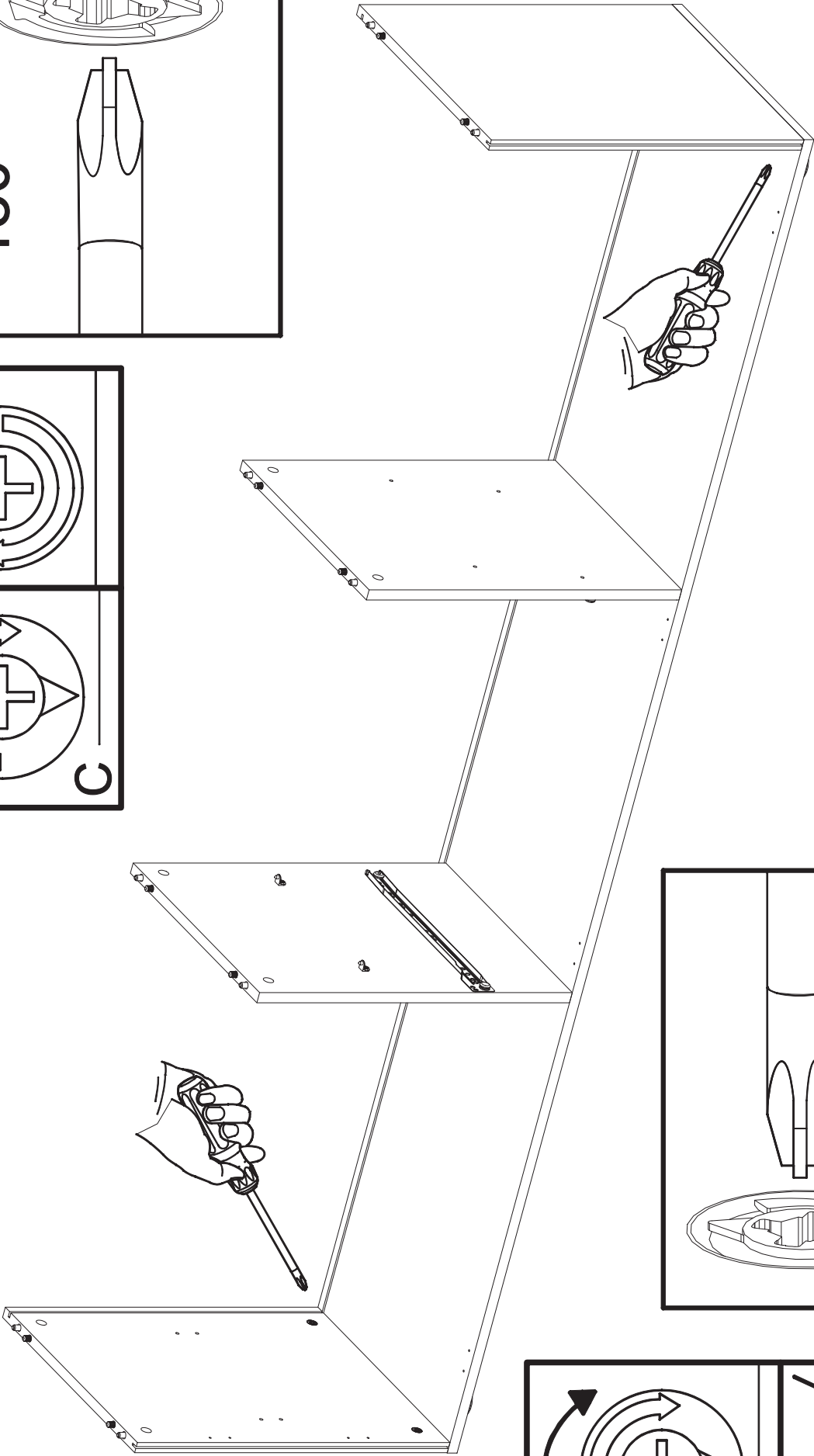
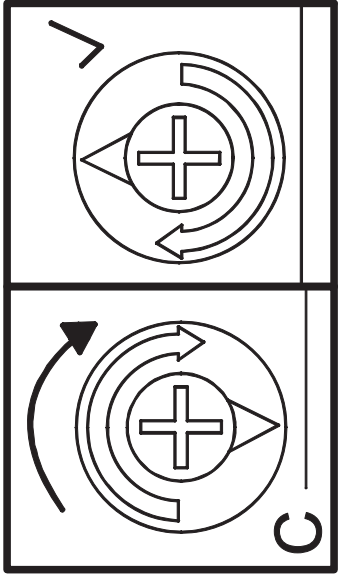
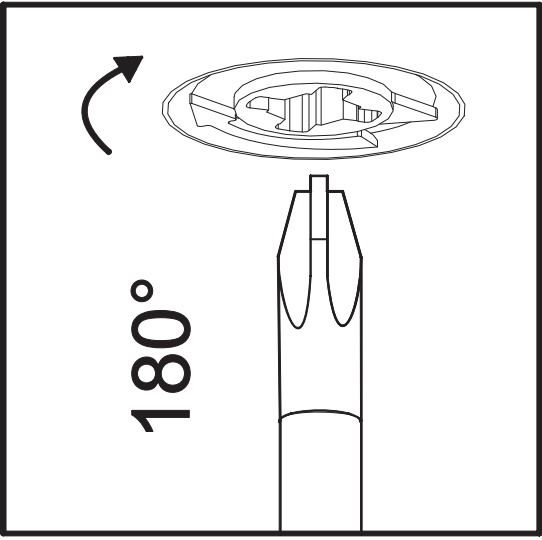

8

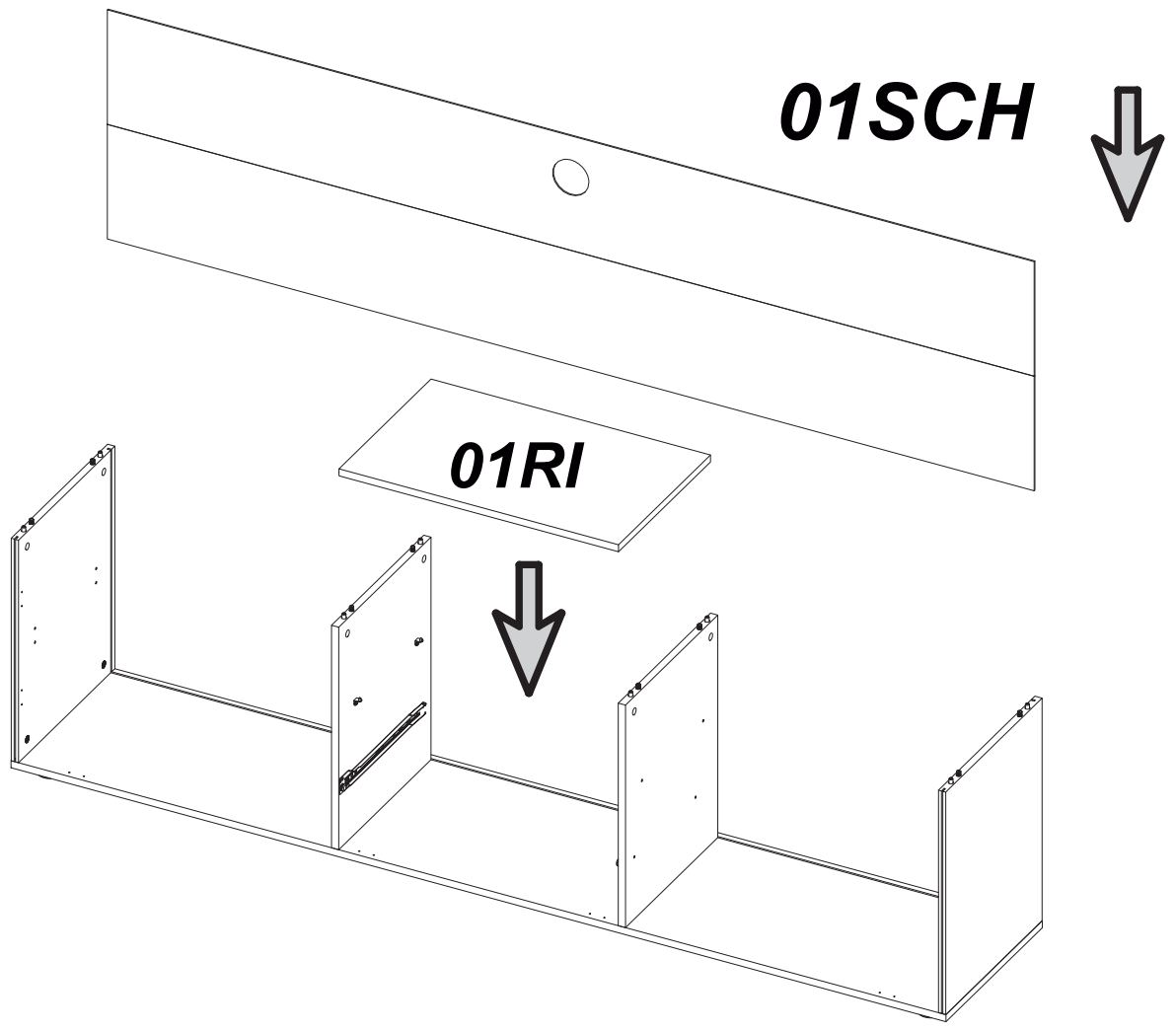

9

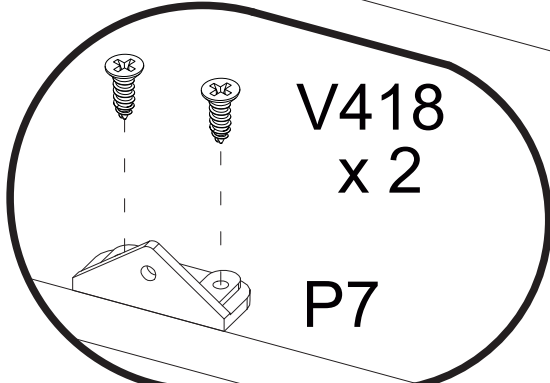
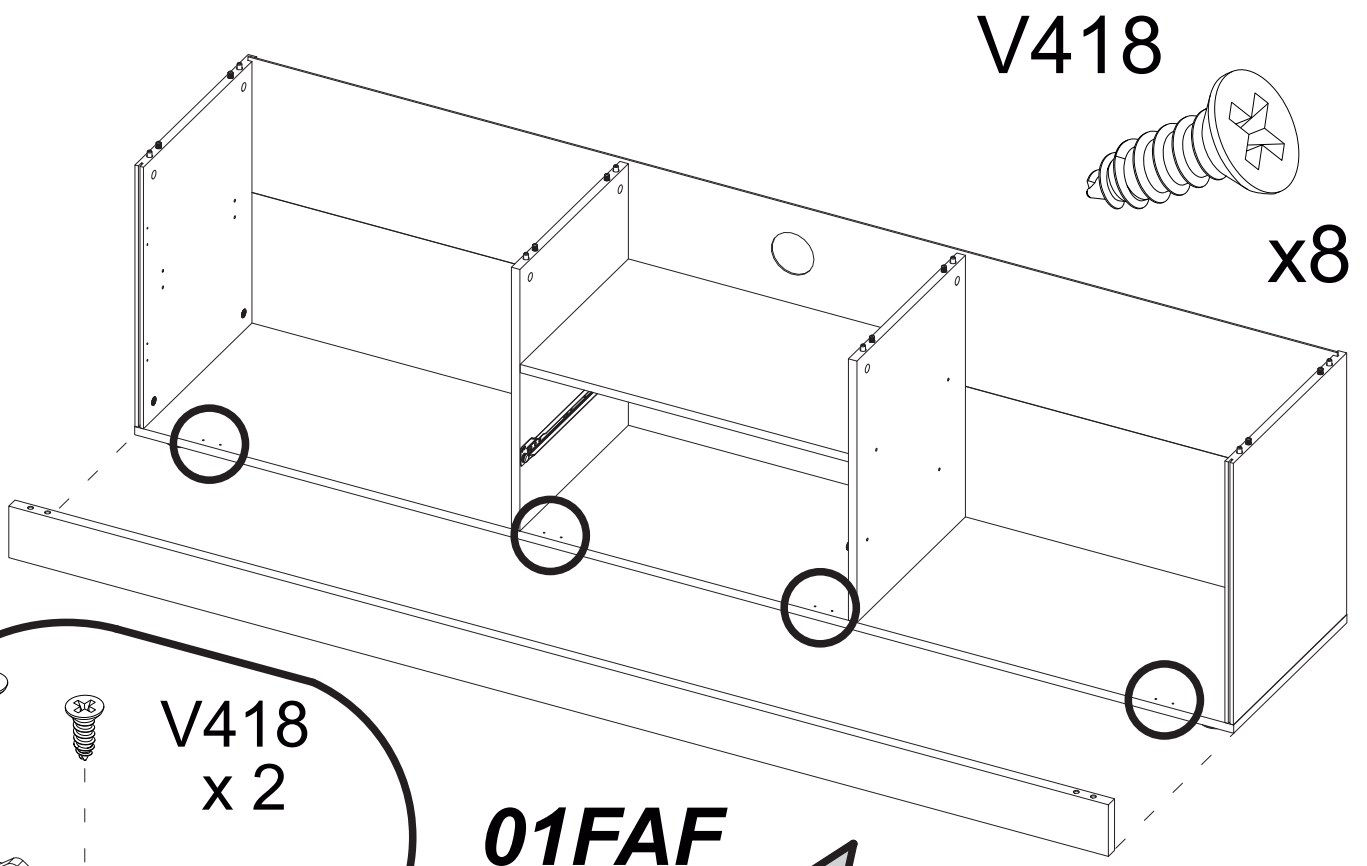

10

**01FA
+
01PETI**

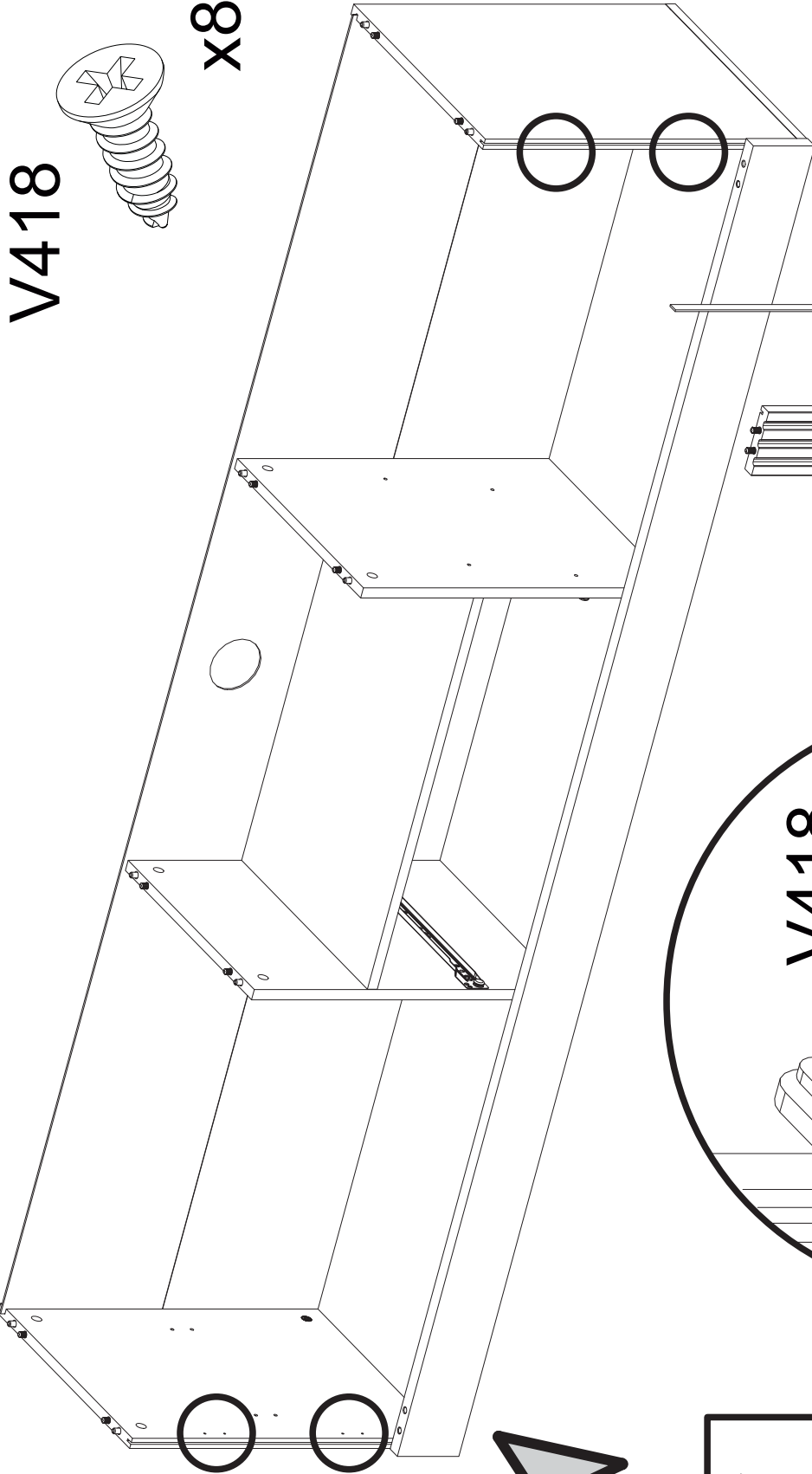

V418

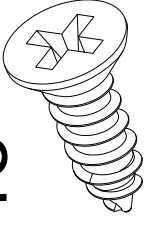

X8

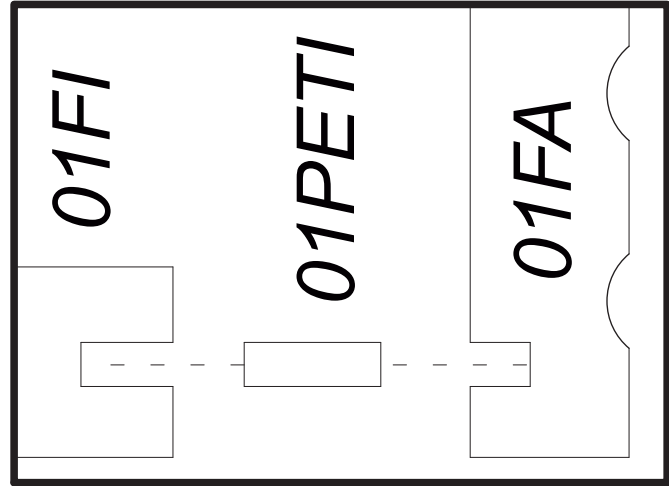

01FI

01PETI

01FA

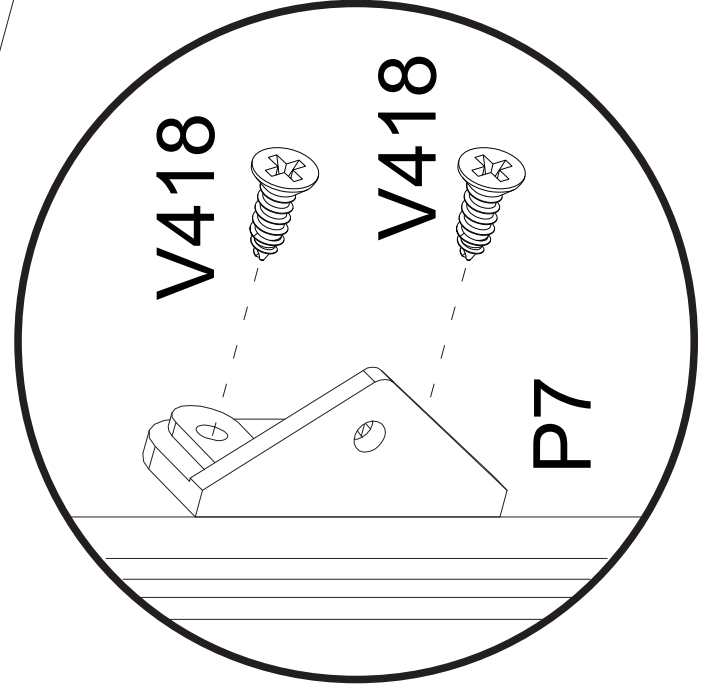

V418

V418

P7

01FA + 01PETI

11

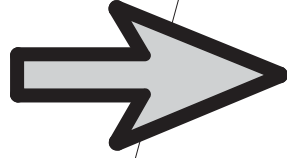
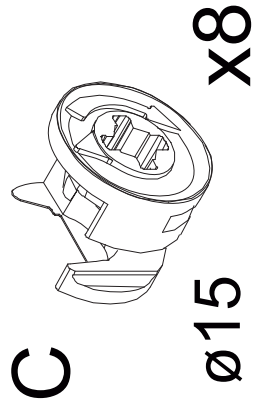

0170

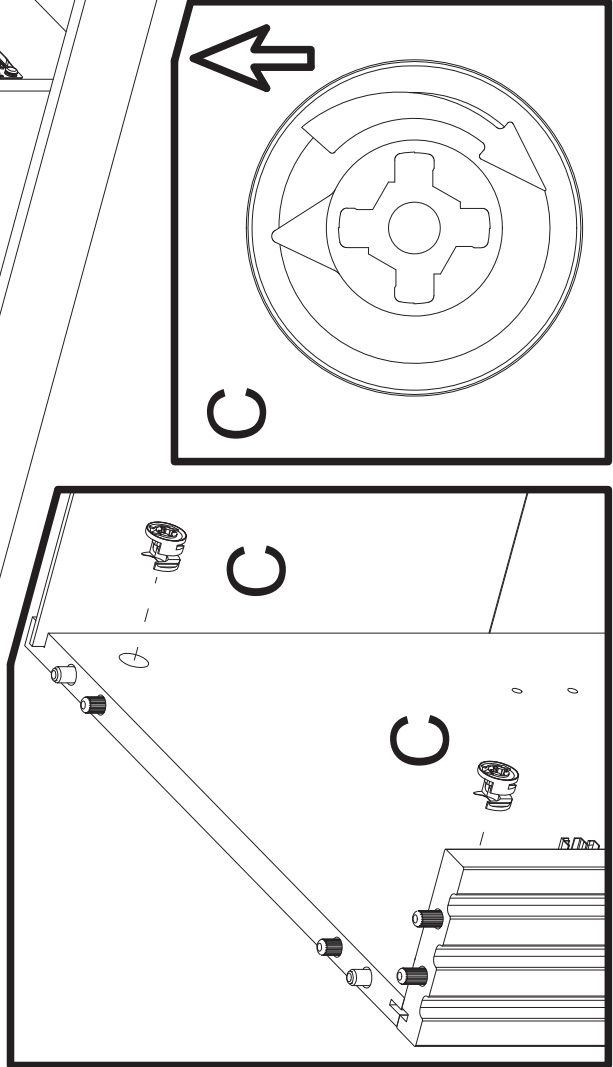
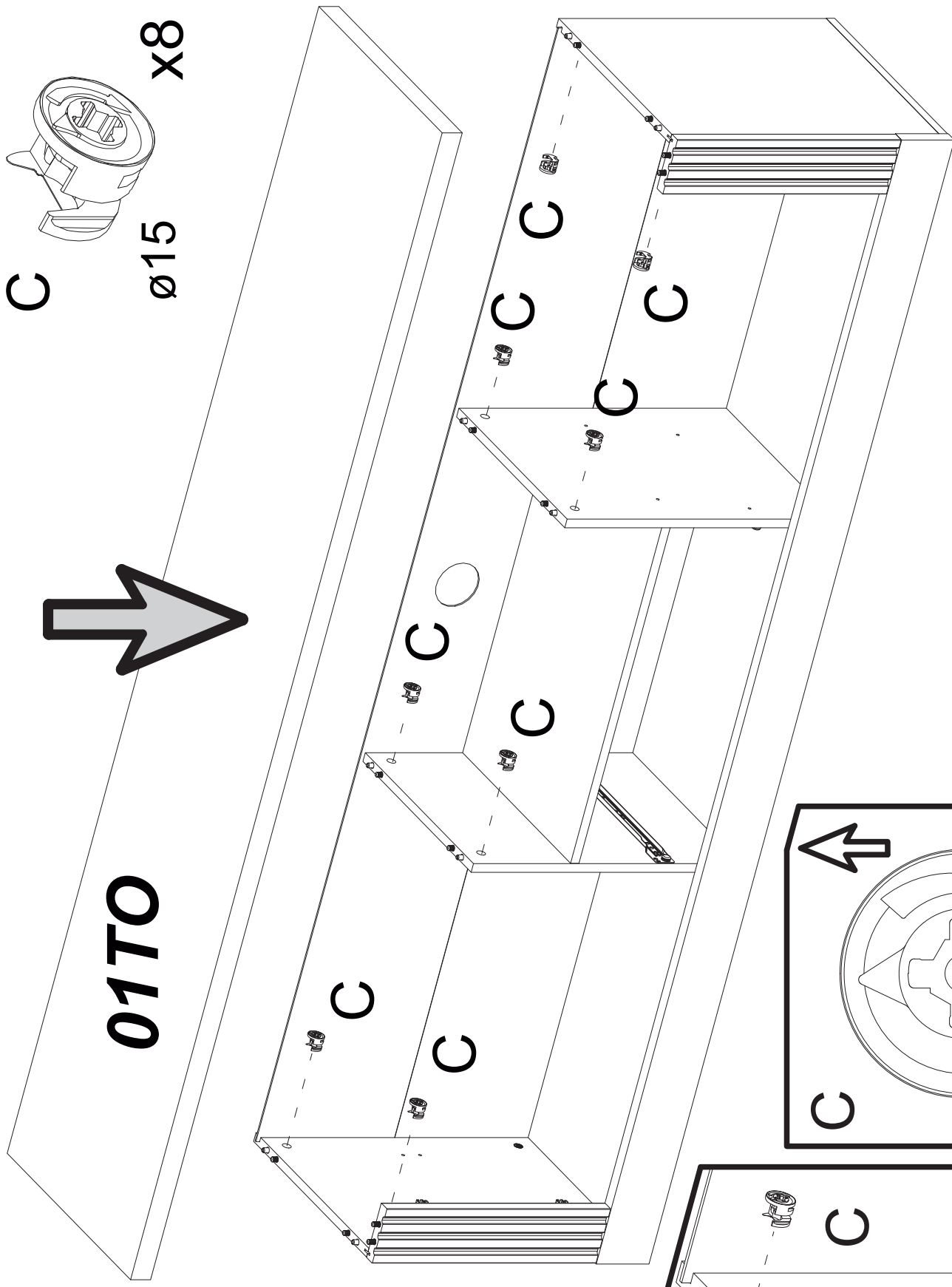

12

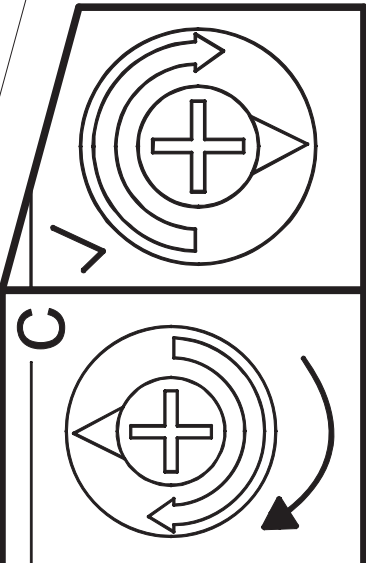
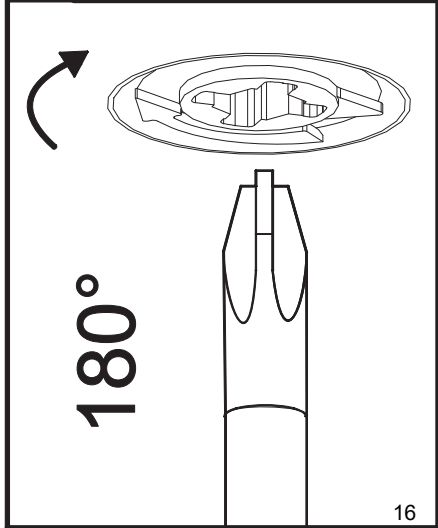
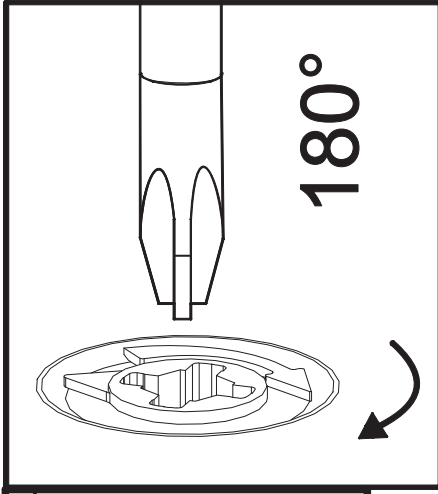
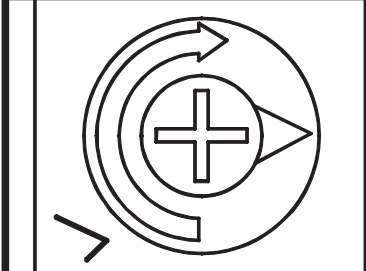
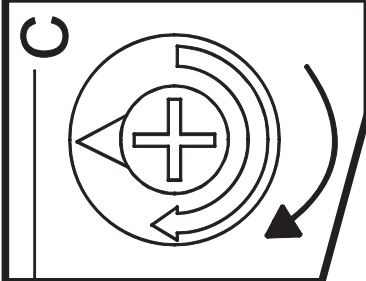
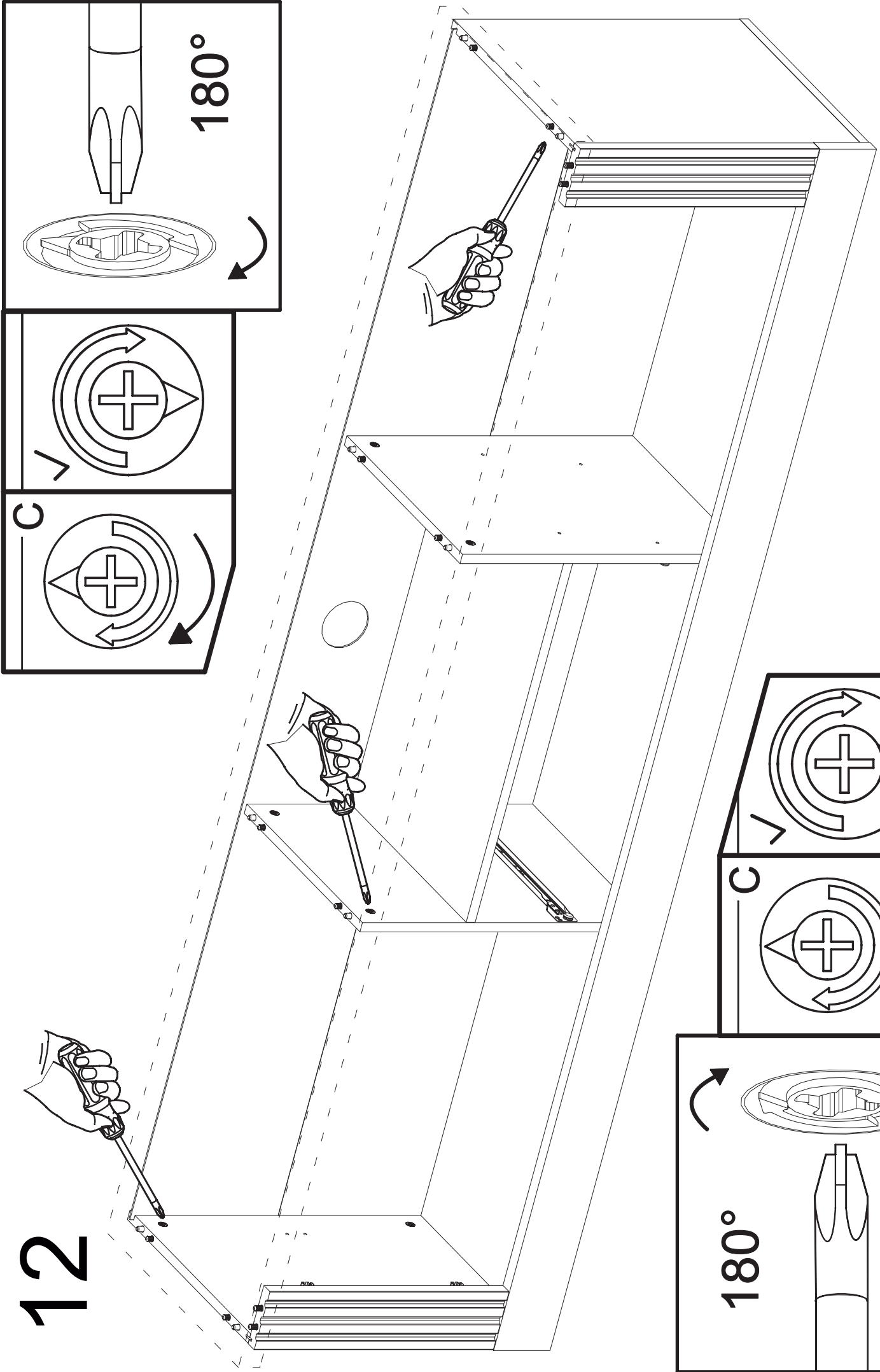

13

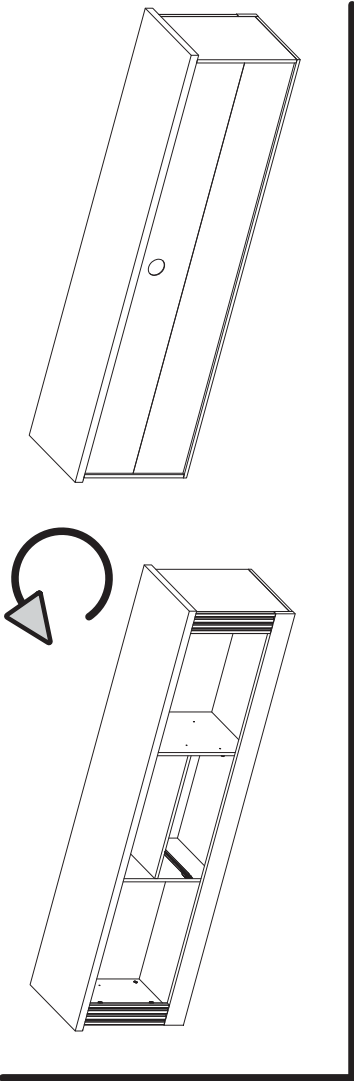
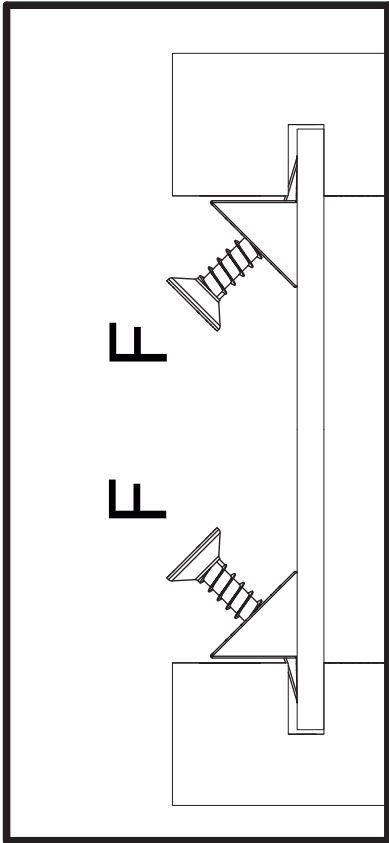

F

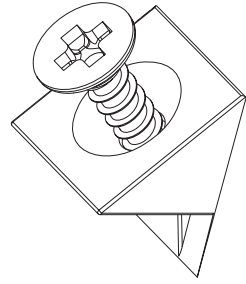

x14

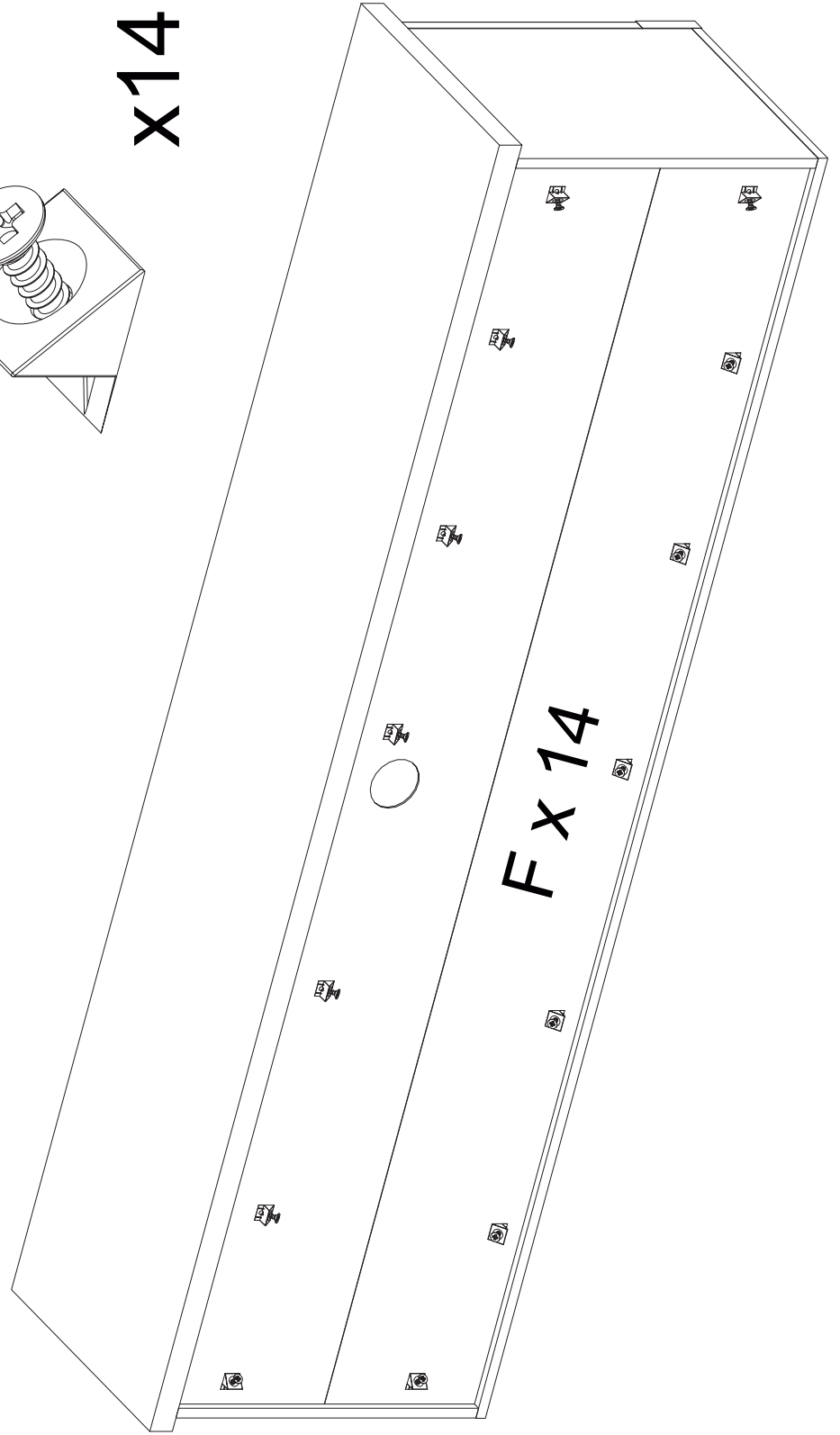
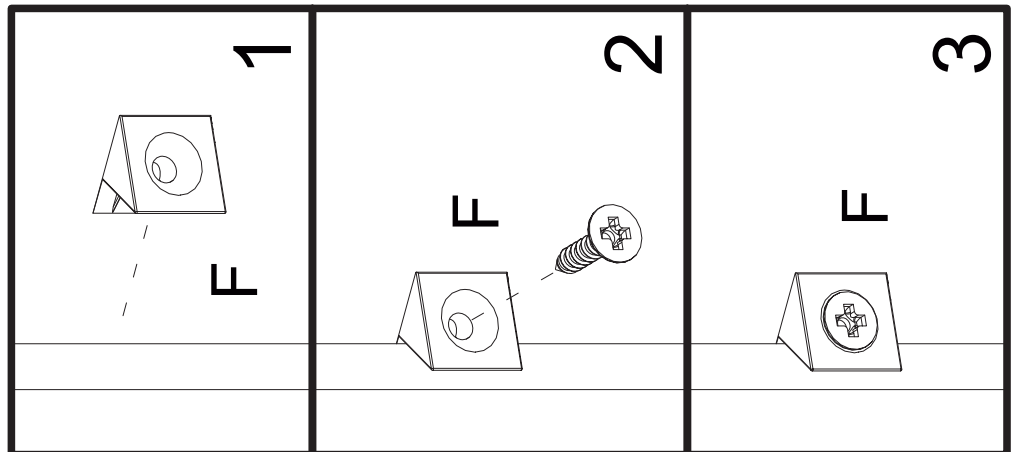

14

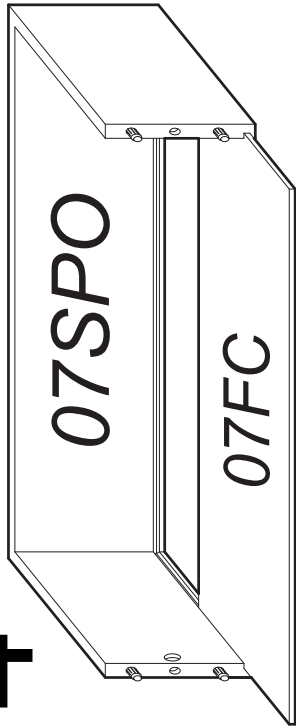

POM F V3516 DR

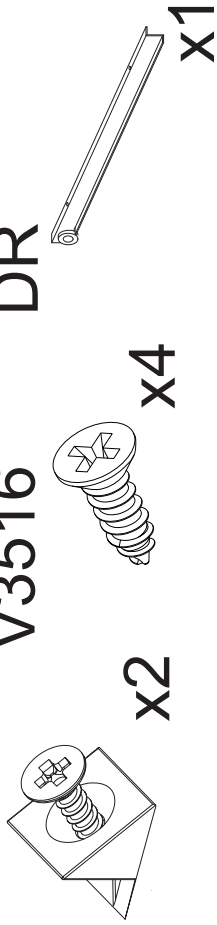

T420 C1 D1 DL

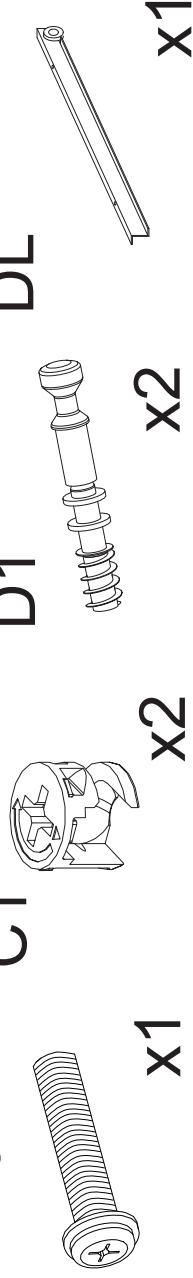

2

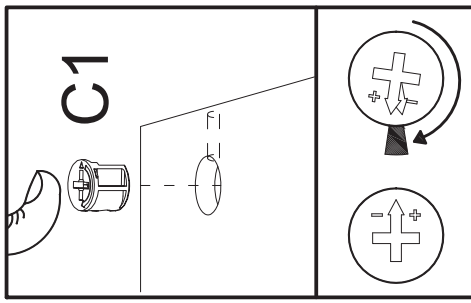
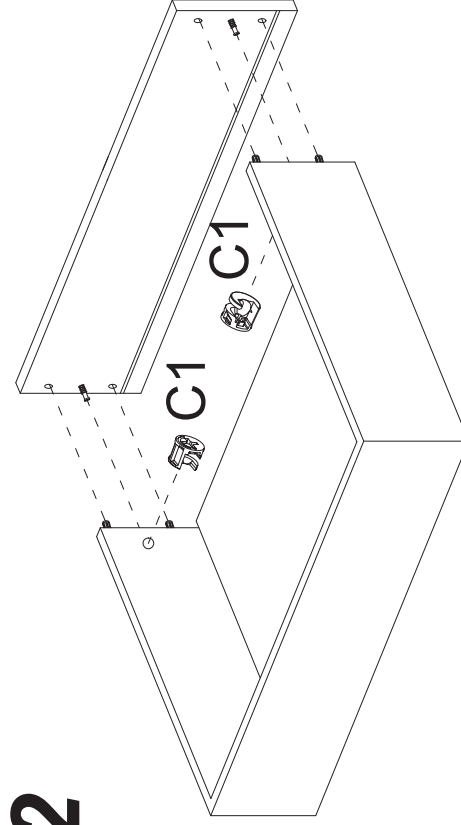

1

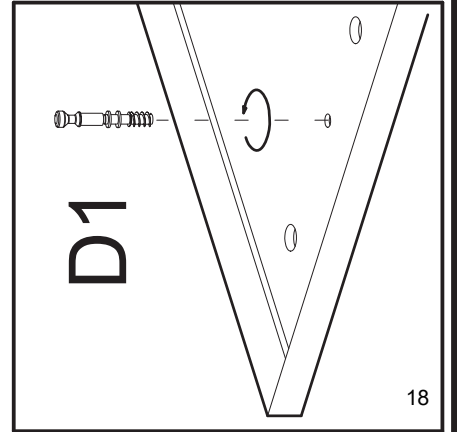
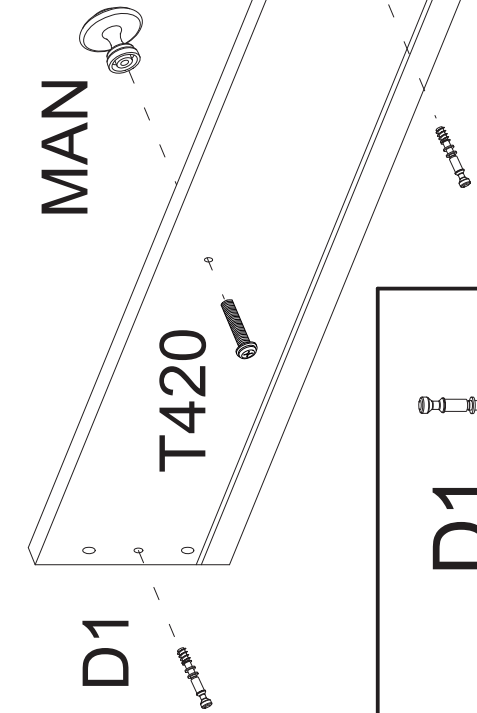

3

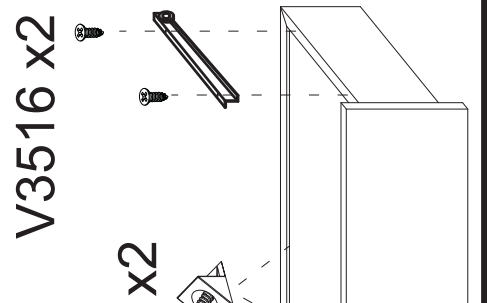
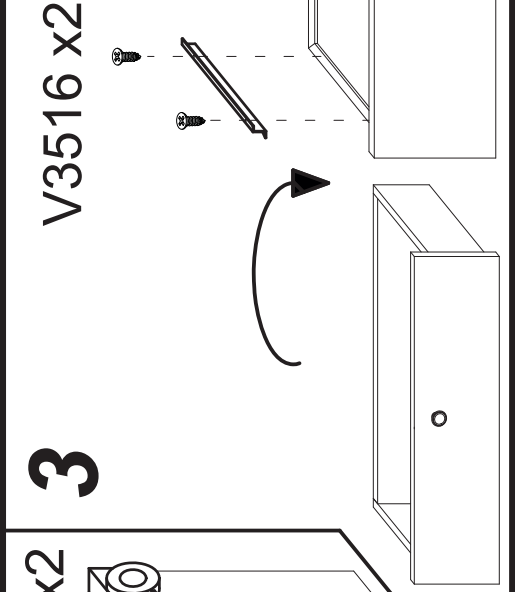
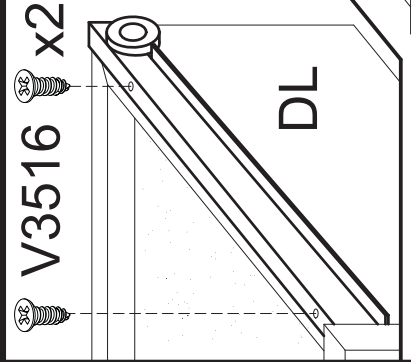



Attenzione!!! Aprire le cerniere prima del montaggio
Attention!!! Open hinges before assembly
Achtung!!! Scharniere vor der Montage öffnen
Attention!!! Ouvrir les charnières avant l'assemblage
Atención!!! Abrir las bisagras antes del montaje



1



2

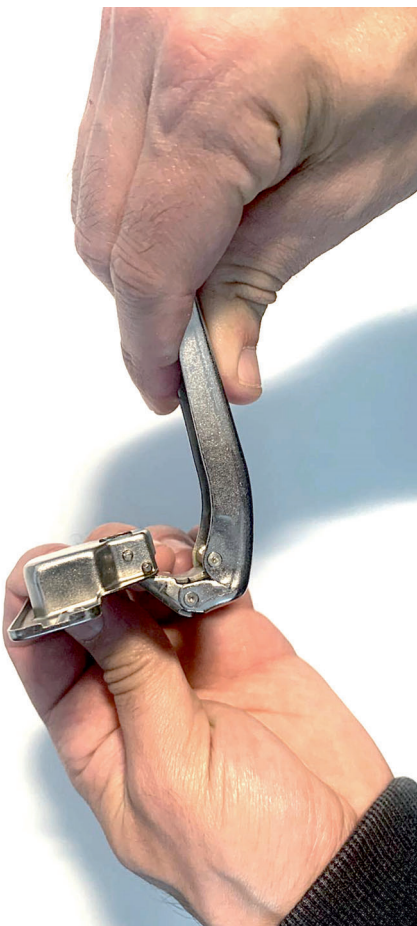

3



15

T420

MAN

V415

C90

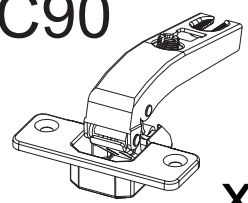
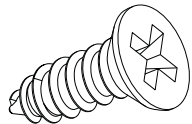
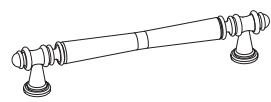
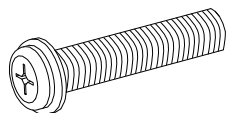

x4

x2

x8

x4

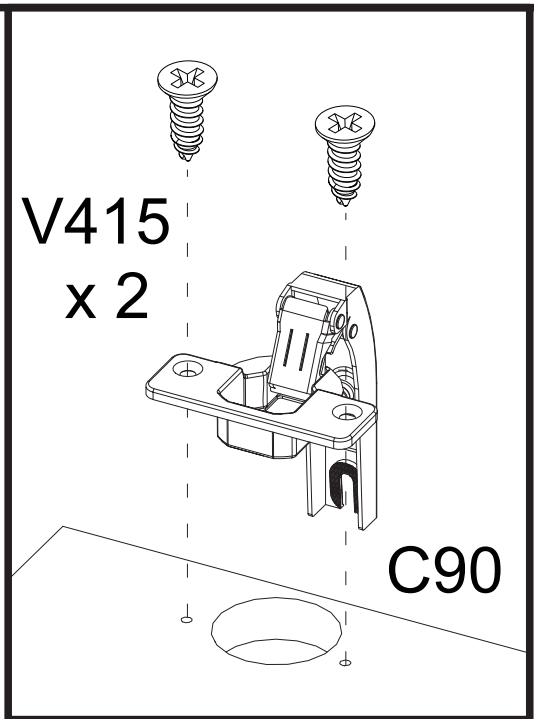

V415
x 2

C90

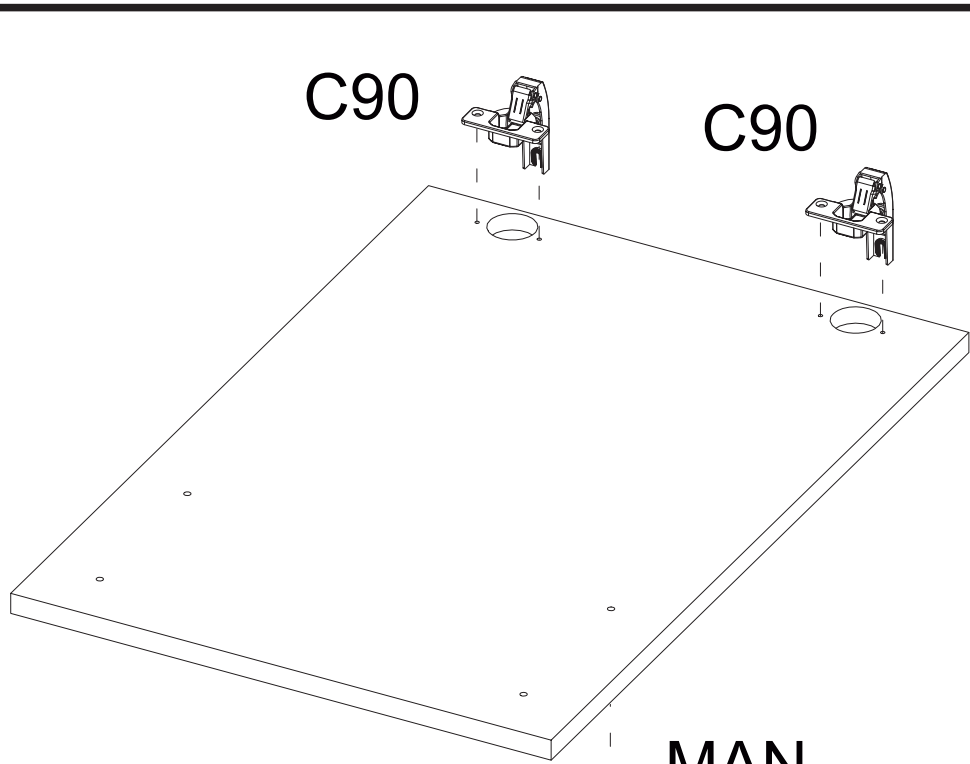

C90

C90

C90

C90

MAN

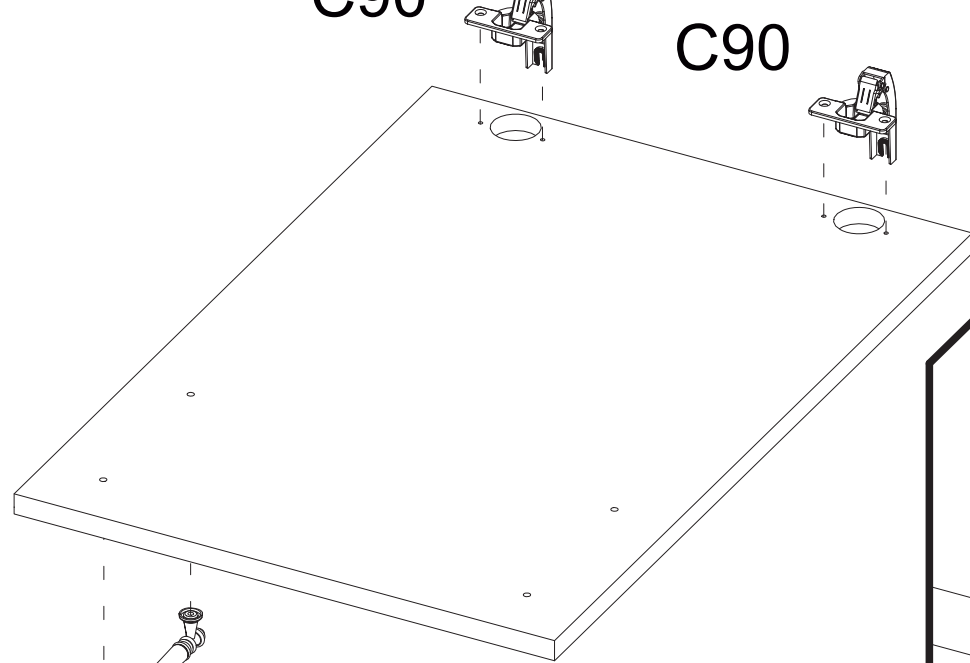

MAN

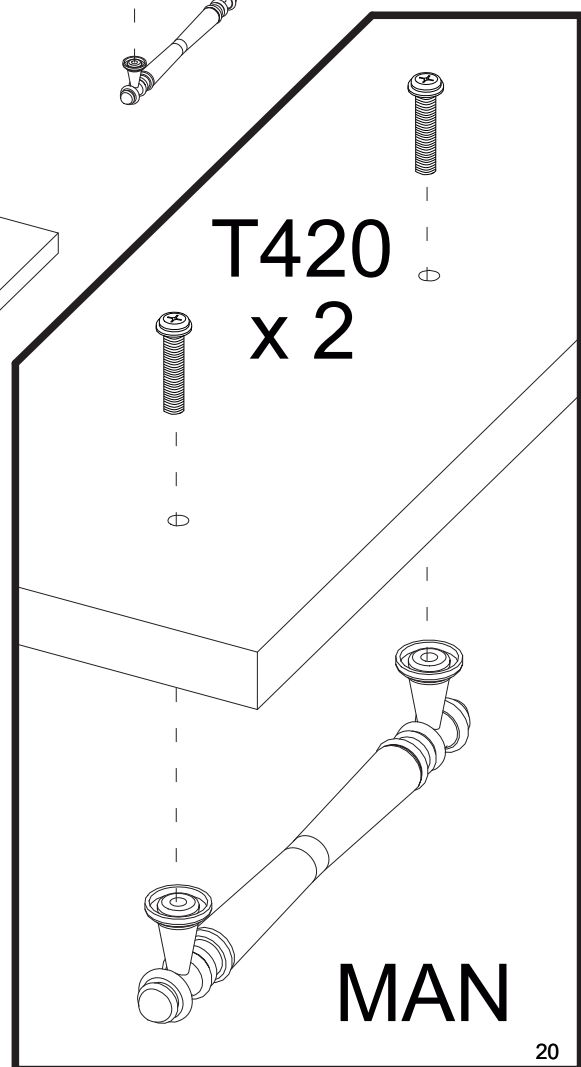

T420
x 2

MAN

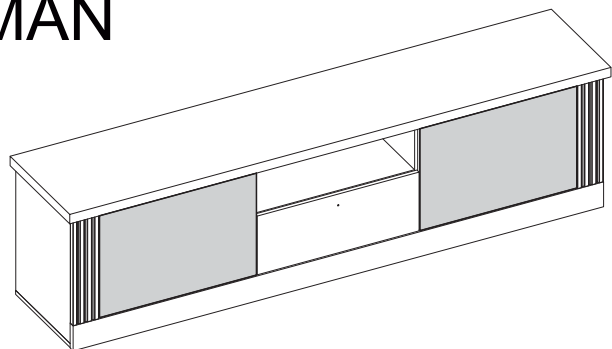

16

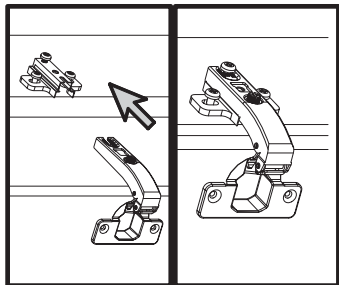

01SP

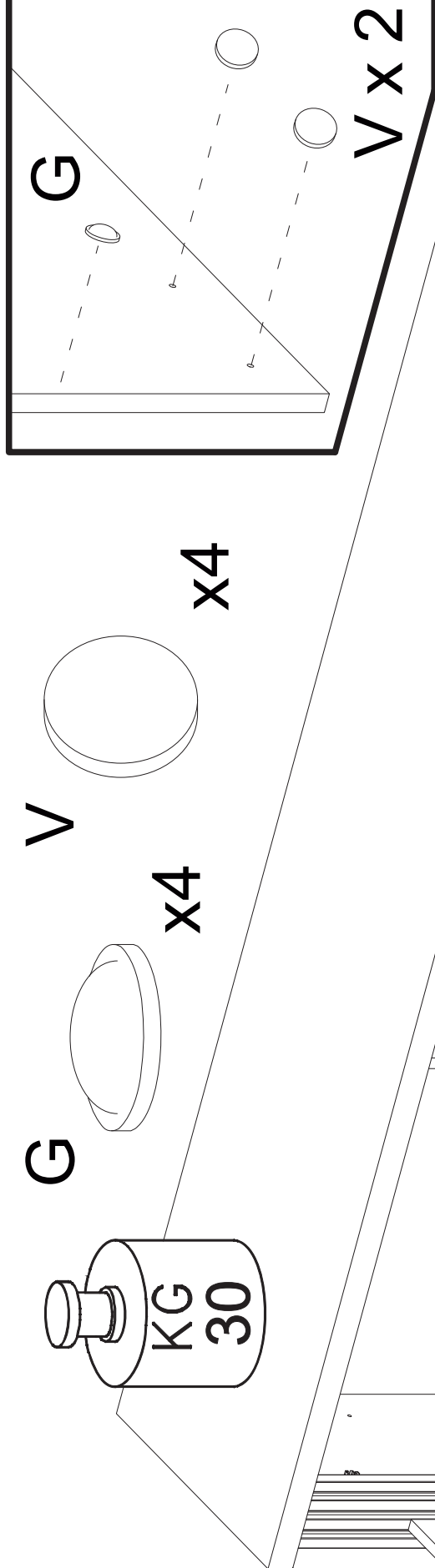
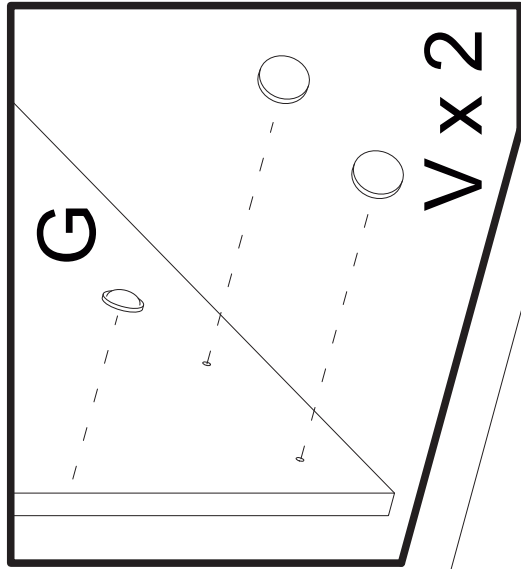
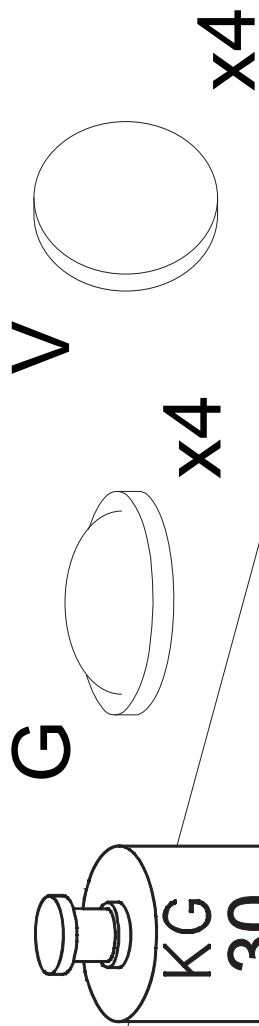

KG 10

KG 5

V x 2



01CA

G



G



V x 2

01SP

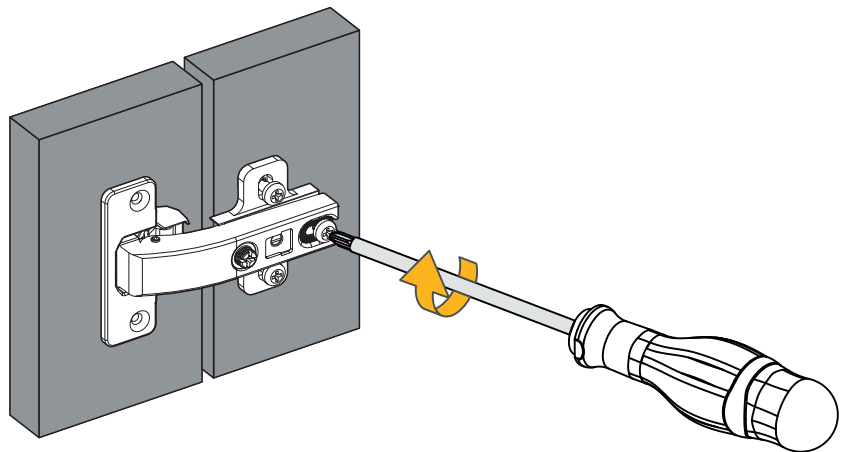
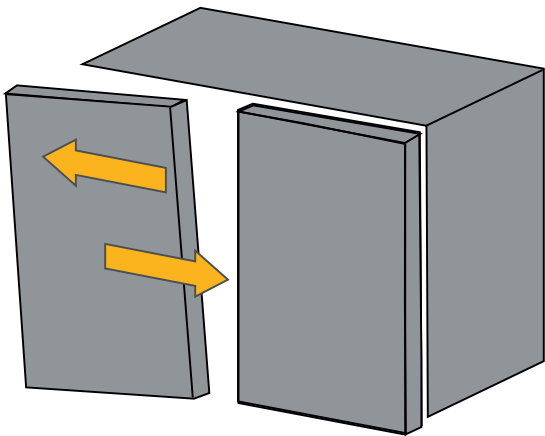
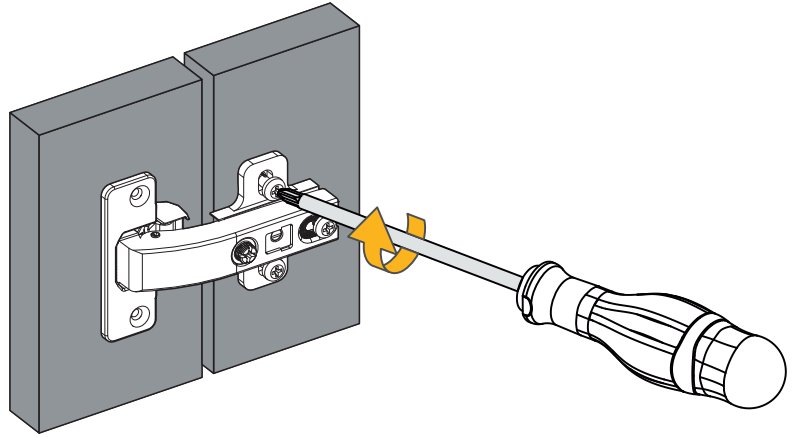
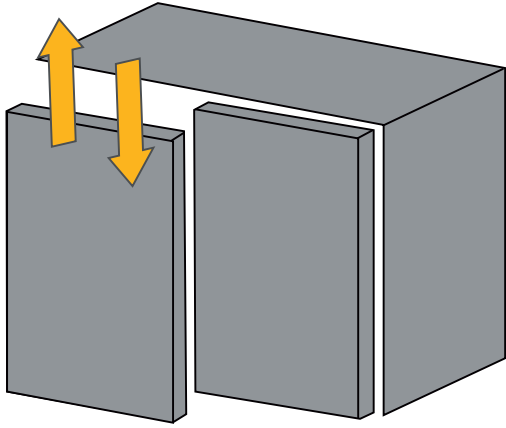
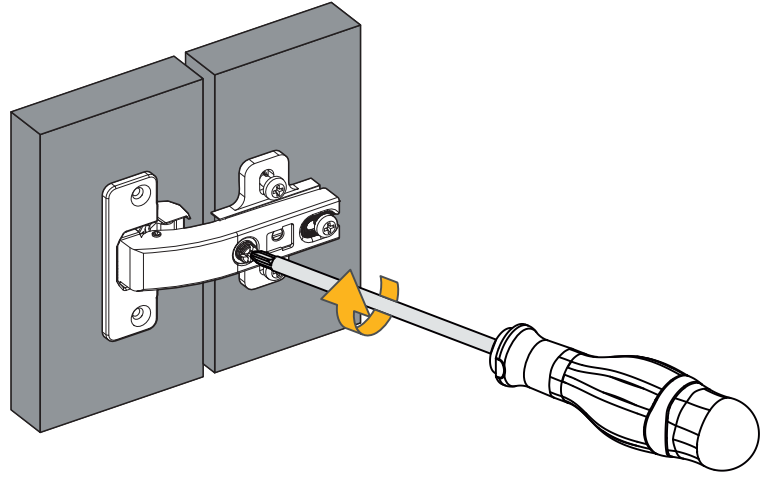
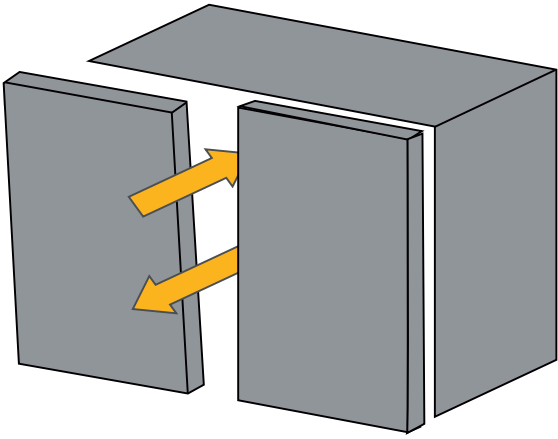

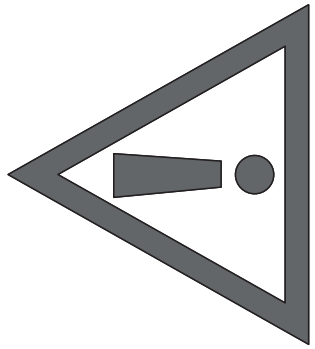

PST

x1

V418

x2

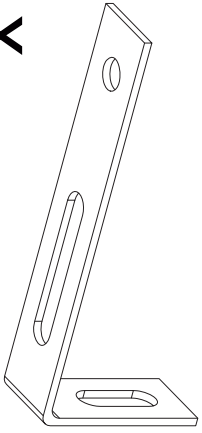
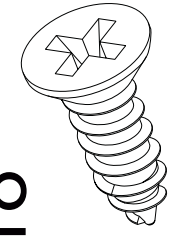

Ø8

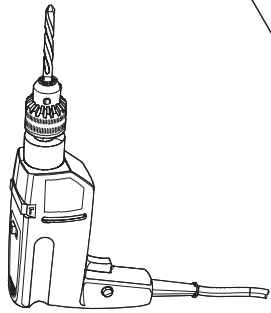

PST

